

SHARP SERVICE MANUAL

CODE : 00ZPCA810SM-E

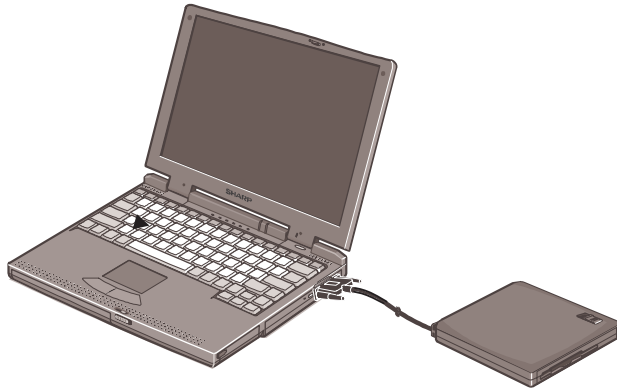

PERSONAL COMPUTER

MODEL PC-A810

CONTENTS

CHAPTER 1. OUTLINE.....	1 - 1
CHAPTER 2. SPECIFICATIONS	2 - 1
CHAPTER 3. DISASSEMBLY AND REASSEMBLY	3 - 1
CHAPTER 4. PRECAUTIONS	4 - 1
CHAPTER 5. RE-INSTALLATION.....	5 - 1
CHAPTER 6. MAIN BOARD CONNECTOR INFORMATION	6 - 1
CHAPTER 7. TROUBLESHOOTING	7 - 1
CHAPTER 8. DIAGNOSTICS.....	8 - 1
CHAPTER 9. BLOCK DIAGRAM	9 - 1
CHAPTER 10. CIRCUIT DIAGRAM AND PARTS LAYOUT	10 - 1

Parts marked with "⚠" are important for maintaining the safety of the set. Be sure to replace these parts with specified ones for maintaining the safety and performance of the set.

SHARP

COPYRIGHT © 2000 BY SHARP CORPORATION

All rights reserved.

Printed in Japan.

No part of this publication may be reproduced,
stored in a retrieval system, or transmitted.

In any form or by any means,
electronic, mechanical, photocopying, recording, or otherwise,
without prior written permission of the publisher.

SHARP CORPORATION
Information Systems Group
Quality & Reliability Control Center
Yamatokoriyama, Nara 639-1186, Japan

1999 March Printed in Japan ⓘ

CHAPTER 1. OUTLINE

Overview of Computer

In the following diagram, the labels in *italics>* refer to the chapter and page number in this manual where you can find more information. The actual appearance of your computer may be slightly different depending on the model.

Front View

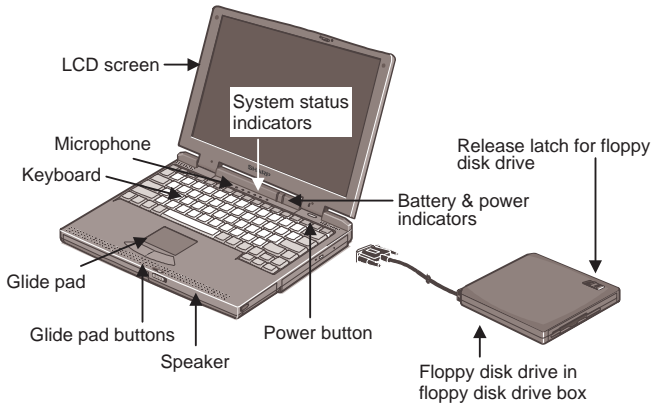

Front View Markings

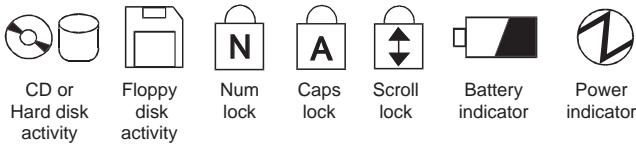

Right Side View

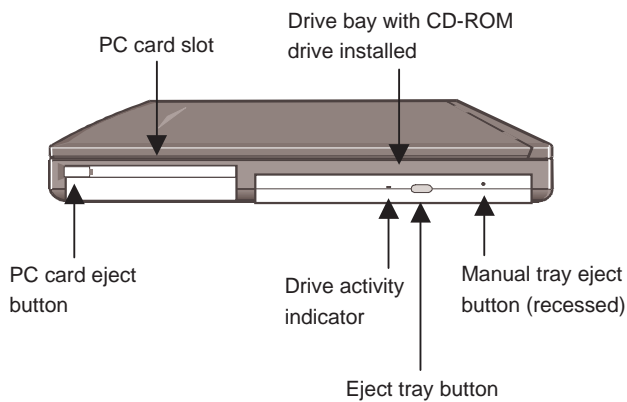

Left Side View

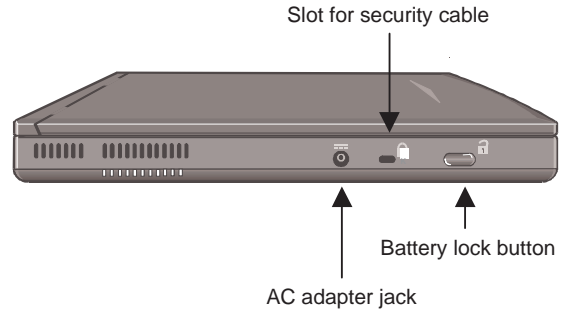

Rear View

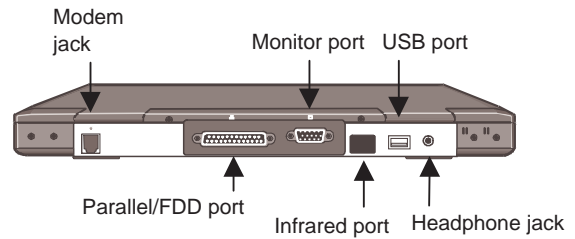

Bottom View

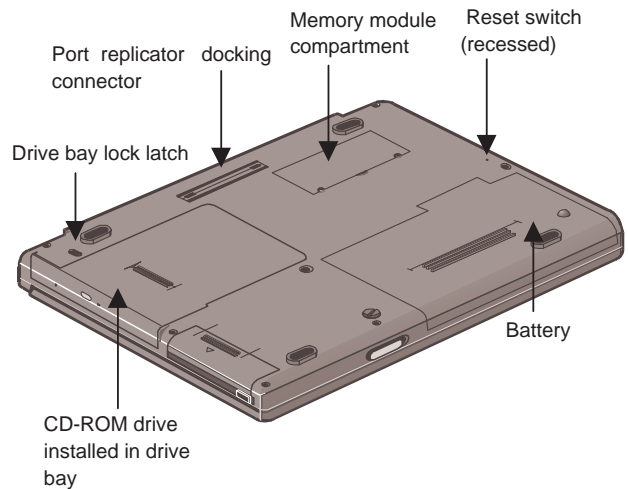

Basic Operations

This chapter describes some of the basic operations of your computer such as using the keyboard, adjusting the display, and so on.

Powering the Computer

You can operate your computer by using the AC adapter to connect to a suitable power outlet. You can also power the computer by the internal Lithium-Ion battery.



Whenever you use the AC adapter to power the computer, the internal battery automatically begins recharging. Recharging continues whether the computer is turned on or off.

Refer to Chapter 3 Battery and Power Management for a full description of battery charging and related information.

Power and Battery Indicators

For proper operations it is important to understand the operation of the power and battery indicators located beside the right-side hinge of the upper cover.

Indicator Meanings

Green Power Indicator		
Icon	Lamp State	Status
	Turned on	Computer is turned on
	Turned off	Computer is turned off
	Slow blinking	Computer is in Standby mode
Tri-color (green/red/orange) Battery Indicator		
Icon	Lamp State	Status
	Turned on orange	Battery is charging
	Turned on green	Battery is fully charged
	Turned on red	Battery low warning
	Flashing red	Critical battery warning
	Flashing orange	Abnormal condition - for example the battery may be installed incorrectly

Resetting the System

You may need to reset the system after adding hardware or software so that your computer recognizes newly installed devices or software. When the message appears after the installation, click OK, Yes, etc., to restart Windows 98.

You can also restart Windows 98 from the Start menu. Select Shut Down, then Restart.

Warm Boot (Software Reset)

If the system is locked up because of a software problem, you can reset or reboot the system by pressing the Ctrl+Alt+Del keys simultaneously. Press the Ctrl+Alt+Del keys again to restart the computer.



Resetting may cause data loss. Use the software reset only if the normal Windows 98 Shut Down does not work because of software malfunction. Although resetting does not damage the system, you may lose the data you are processing.

Power Switch

You can turn off the computer with the power switch if the system has hardware or software problems so that you can't use the Windows Shut Down command or the software reset. In this case, you need to hold the power button down for more than four seconds.

Reset Switch

If all other methods fail, you can reset the computer by pressing the hardware reset switch. The hardware reset switch is in a recessed location on the base of the computer. Activate the switch with a straightened paper clip or similar implement.

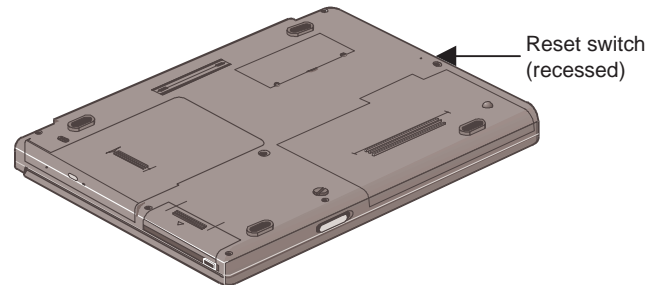

Using the Keyboard

The built-in keyboard includes all the functions that you find on a full-sized keyboard. In addition, the keyboard has built-in hot keys that you can use to control some of the functions of the computer.

The illustration below shows the location of some important keys on your keyboard.

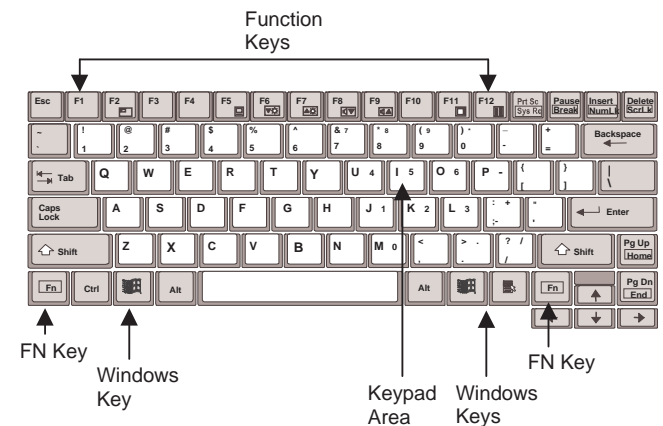

Function Keys

On their own, the operation of the function keys is usually determined by the software application that you are running. In combination with the Fn key they create hot-keys that you can use to control some of the computer functions. Icons embossed on the function key keycaps indicate the hot-key function.

Embedded Keypad

The numeric keypad is embedded in some of the right-side alphanumeric keys. The keypad functions are embossed in the upper right corner of the keypad keycaps. You activate the embedded numeric keypad by pressing the Num Lk key (press Fn+Insert). Repeat the keystroke to turn off the embedded keypad.

Windows Keys

There are two different Windows keys as shown below. The keyboard repeats the Windows Start key on either side of the Space bar.

 Windows Start Key. This key opens the Windows Start menu on the taskbar. In combination with other keys it provides short cuts to some Windows functions. See Windows help for more information.

 Windows Pull-down Menu key. When an item is selected and this key is pressed, it pulls down a menu if one is available. It is similar to the right click of a mouse or glide pad.

Fn (Function) Key Combinations

You can activate hot-key system controls and various embedded keystrokes by holding down one of the two Fn keys and then pressing any of the keys embossed with an icon or boxed text on the lower half of the key.

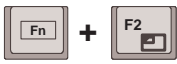
 Pops up an information box in the upper left corner of the screen - see the section Pop Up Power Management Information Box below

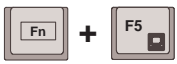
 Switch display between the built-in screen, an external monitor, and a simultaneous display - see Chapter 4 Connecting Peripherals

 Press keys to decrease screen brightness - see Adjusting the Display below

 Press keys to increase screen brightness - see Adjusting the Display below

 Press keys to decrease the audio volume - see Controlling the Audio below

 Press keys to increase the audio volume - see Controlling the Audio below

 Turns off the display backlight on the built-in screen - see Adjusting the Display below

 Puts the system into suspend mode - see About Standby Mode in Chapter 3.

 Returns the Sys Request keystroke

 Returns the Num Lock keystroke - activates the embedded numeric keypad

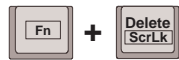
 Returns the Scroll Lock keystroke

 Returns the Home keystroke

 Returns the End keystroke

Pop-Up Power Management Information Box

When you hold down the Fn key and press the F2 function key, a pop-up information box appears for about five seconds in the top left corner of the display. The information box has the following information:

BATT	Shows remaining battery capacity as a percentage	
PM	Shows status of the power management setting in the setup utility	
	OFF	Power management is disabled
	ON	Power management is enabled
AC	DC	Power management is enabled only when using battery power
	Shows if the AC adapter is connected or not	
	OFF	AC adapter is disconnected
	ON	AC adapter is connected
BIOS	Shows BIOS version number	

Using the Glide Pad

Your computer has a built-in pointing device called a glide pad. The glide pad consists of the glide pad surface, a left button and a right button.

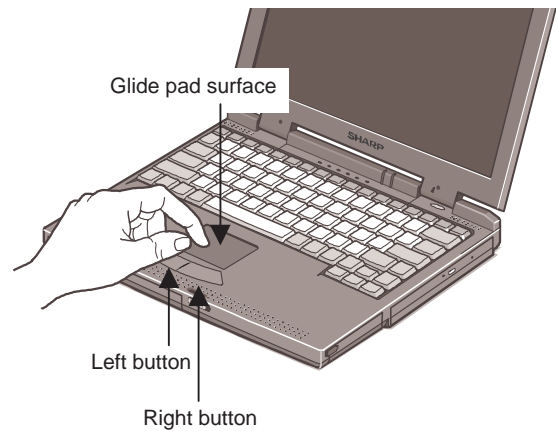

Using the Glide Pad

When you slide your finger across the glide pad surface, the pointer on the screen moves in the same direction as your fingertip.

Clicking and double-clicking

To click or double-click objects, you can use the left button, just as you do when using a mouse. You can also emulate a left button click or double-click by tapping once or twice with your fingertip on the glide pad surface. Clicking the right button pulls down a menu if one is available. This is the same function as the right click of a mouse.

Drag and Drop

You can drag and drop objects on the Windows desktop as follows:

1. Position the pointer over the object.
2. Press and hold down the left button.
3. Drag the object by moving your fingertip over the glide pad surface.
4. Drop the object into place by releasing the left button.



- Do not use a pointed object, such as a pen or pencil to operate the glide pad, You might scratch or damage the surface.
- Do not operate the glide pad with a moist finger. This may cause the glide pad to operate incorrectly.

Changing the Glide Pad Configuration

You can change the way the glide pad operates in the Mouse Properties window. From Windows Start menu, select Settings - Control Panel and double-click Mouse to open up the Mouse Properties window. Click on any of the tabs; Buttons, Pointers or Motion. Use the checkboxes, drop down menus, and so on, to configure the glide pad so that it operates to your satisfaction.

Reading the Status Indicators

As well as the Power and Battery Charge indicators discussed before, your computer has five more status indicators located above the keyboard between the hinges of the upper cover. The indicators are identified by icons printed above each lamp.

Indicator Icon	System Status
	This indicator turns on when your computer is reading or writing to the hard disk drive or a CD in the CD-ROM drive.
	This indicator turns on when your computer is reading or writing to a disk in the floppy disk drive.
	This indicator turns on when the Num Lock key has been pressed and the embedded numeric keypad is activated.
	This indicator turns on when the Caps Lock key has been pressed and the keyboard is in Caps Lock mode.
	This indicator turns on when the Scroll Lock key has been pressed and the cursor arrow keys are in scroll lock mode.

Adjusting the Display

The most important adjustment you can make to the display is to set it to the best viewing angle. The display contrast decreases if you look at it from a wide angle above or below, or from side to side.

Changing the Brightness

Change the screen brightness by using the Fn+F6 and Fn+F7 hot keys.



Press keys to decrease screen brightness



Press keys to increase screen brightness

When you press the screen brightness hot keys to adjust the display, a pop-up screen brightness meter appears in the upper left corner of the display. You can use the pop-up meter as a visual guide to set the screen brightness.



Decreasing the screen brightness is an effective way of reducing the power consumption of your computer when you are operating the computer on battery power.

Turning off the Display

You might want to turn off the display when you are not using your computer for short periods. This can help reduce power consumption. Use the display power down hot keys Fn+F11.



Turns off the display on the built-in screen

You can turn the display back on by pressing any key on the keyboard.

Changing the Display Properties

The Windows Display Properties window lets you make many different kinds of changes to the appearance of the screen under Windows.

Place the screen pointer on any empty area of the Windows desktop and click the right glide pad button to pull down a menu. Click on Properties to open the Display Properties window. Use the tabs on the Display Properties window to make adjustments to the following display properties; Background, Screen Saver, Appearance, Effects, Web, and Settings.

Using the Settings Tab

The Settings tab lets you make changes to the resolution and color depth of the display.

The standard display setting for your computer is a resolution of 1024 x 768 pixels. If you select a smaller resolution, the image on the built-in display will stretch to occupy the whole screen. This might cause the image to be somewhat deformed. If you select a larger resolution, the display will extend beyond the edges of the built-in screen. You can scroll the enlarged display by moving the screen pointer to the edges of the display.

The standard color depth for your computer is High Color (16bit). You might need to change down to a lower color depth in order to run some computer programs or games.

Advanced Settings and Switching the Display

Your computer has hot keys to switch the display when you are connected to an external monitor. In the Display Properties window, the Advanced settings button in the Settings tab window has other options for switching the display including a dual independent display that lets you run separate applications on the built-in screen and an external monitor. Turn to Connecting an External Monitor in Chapter 4 for more information on this topic.

Controlling Audio

Your computer is installed with a built-in speaker and a built-in microphone. You can use Windows Entertainment Accessories to play CDs, record messages and sound, play computer games with sound tracks, and so on.

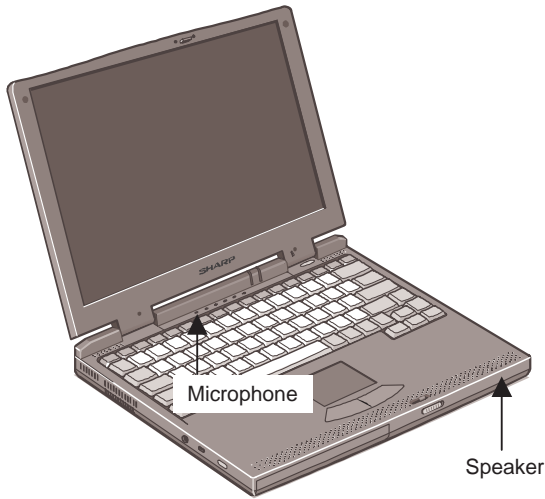

You can control the audio volume by using the audio hot keys Fn+F8 and Fn+F9.

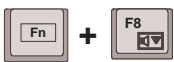

Press keys to decrease the audio volume

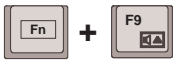

Press keys to increase the audio volume

You can use the Windows volume control meter to visually judge the audio level setting.

Using the Floppy Disk Drive Externally

To remove the floppy disk drive from the optional floppy disk drive box (CE-FC01), press the lock latch on the top edge of the cover and pull the floppy disk drive out of the box.

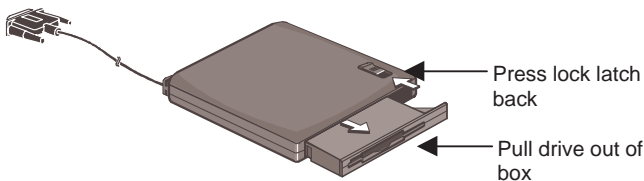

To use the floppy disk drive as an external drive, follow the steps below:

1. Install the floppy disk drive into the floppy disk drive box. Simply slide the drive in until it clicks into place.
2. Shut down your computer.
3. Plug the cable from the floppy disk drive box into the parallel/FDD port on the rear edge of the computer.
4. Restart your computer.

Battery and Power Management

This chapter explains how to charge your computer's internal battery and keep it in good condition. It also explains how you can use the power management features to maximize battery life while operating under battery power.

Battery Pack

The removable battery pack is installed in the base of the computer. If you have an optional spare battery pack (Model CE-BL08) you can double the operating time of your computer when there is no AC power available.

The length of time you can run your computer using a fully-charged battery pack is variable. If you are using applications that make heavy use of peripheral items such as the hard disk drive or the CD-ROM drive, the battery discharges in a shorter time. If your battery is older and has already been through many cycles of charging and discharging, it stores less charge. Finally, the temperature and environment can influence battery life.

After you have operated your computer using battery power only, you will have a good idea of how long it takes a fully-charged battery to discharge. Use this time as a standard. If the battery begins discharging in a significantly shorter time, and you are not using your computer in a different manner, or have not changed the power management settings, it may indicate a battery problem.



After repeated cycles of charging and discharging, all batteries store less charge. Expect a gradual decrease in battery life after a few hundred cycles of charging and discharging. When battery life becomes too short, you can purchase a replacement battery pack (Model CE-BL08).

Battery Charging

The battery pack begins charging anytime your computer is connected to AC power using the AC adapter.

If the battery pack is fully discharged and your computer is turned off or in standby mode, the battery pack fully recharges in about 2 hours.

If the battery pack is fully discharged and your computer is turned on, the battery pack fully recharges in about 4 hours.



Your computer monitors the internal temperature of the unit. If the unit gets critically hot, battery charging (which generates some heat) is interrupted until the temperature decreases. This can account for slightly longer battery charging times.

You can track the charging status of the battery pack using the battery indicator located next to the power indicator. The battery charge indicator shows the following conditions:

Tri-color (green/red/orange) Battery Indicator		
Icon	Lamp State	Status
	Turned on orange	Battery is charging
	Turned on green	Battery is fully charged
	Turned on red	Battery low warning
	Flashing red	Critical battery warning
	Flashing orange	Abnormal condition - for example the battery may be installed incorrectly

Battery Low Warnings

The battery low warnings are set using the Windows Power Management Properties application. See later in this chapter for a full discussion of this topic.

The Power Management Properties application lets you set a Low Battery Alarm and a Critical Battery Alarm. The alarms are triggered when battery charge decreases to a user-defined percentage set in the Power Management Properties application.

We recommend that you set the Low Battery alarm to about 10% and the critical battery alarm to about 3-5%. The battery charge percentages are not extremely accurate and the power consumption of different applications are not identical, so it's important to allow for a margin of error. The primary aim is to save your data before the system shuts down when the battery is fully discharged.

Responding to a Low-battery Condition

Following the battery low alarms that you have set, we recommend that you save your work and shut down your computer when there is about 5% of battery charge remaining. In this condition, you can be confident that you have enough power to power the hard disk drive or floppy disk drive and save even the longest of files.

After you have shut down your computer in a low battery condition, don't try to restart the computer until you have replaced the discharged battery with a charged battery pack, or connected the computer to a power outlet using the AC adapter.

Battery Conditioning

If you feel that the battery charge meter in Windows is becoming inaccurate, we recommend that you "condition" the battery using the following steps below.



The following procedure helps to keep your battery in good condition so we suggest that you carry out the procedure each time you complete about 30 cycles of charging and discharging the battery pack.

1. Connect your computer to a power outlet with the AC adapter. Leave the computer connected to the power outlet until the battery indicator turns green to indicate that the battery is fully charged.
2. Turn on the computer.
3. When the Sharp logo appears with the prompt <ESC> for diagnostic screen, <F2> for Setup, press F2 to enter the setup utility.
4. In the Power page of the setup utility, highlight the item PM Control. Press the Space bar to change the value of this item to Disabled.
5. Go to the Exit page of the setup utility, highlight Exit Saving Changes and press Enter. Press Enter again when the dialog asks for confirmation.
6. When the system restarts and the Sharp logo and prompt appear, press F2 again to enter the setup utility.
7. Disconnect the AC adapter from the computer and leave the computer turned on and the setup utility open until the battery completely discharges and the computer shuts down automatically. This might take as long as 2 hours.
8. Connect the AC adapter to the computer and leave it connected until the battery is fully charged.
9. After you have completed the conditioning procedure, return the power management setting in the setup utility to the original state.

Setup Utility

This chapter describes how to run the setup utility to change settings on your computer.

Running the Setup Utility

With the setup utility, you can customize the system configuration information, such as time and date, port assignments, passwords, or power management settings. The information you have specified is saved in a special area called CMOS RAM, which the system reads every time you turn on the computer.

Contents of the Setup Utility

The setup utility consists of six menu pages, as follows:

- Main: Basic system configuration
- Advanced: Device interface configuration (I/O ports, etc.)
- Security: Password settings
- Power: Power management (battery saving settings)
- Boot: Defines where the system boots from
- Exit: Exit the setup utility or return to the default values

Entering and Exiting the Setup Utility

1. Turn on the computer.
2. When the Sharp logo appears with the prompt Press <Esc> for diagnostic screen, <F2> for Setup, press F2.
3. Change the desired settings.
4. Press Esc to select the Exit Page.
5. Select one of the exit methods, and press Enter.
6. When the message Setup Confirmation appears, press Enter again. The system restarts.



To turn off the computer when the setup utility is open, press the power button.

Using the Setup Utility

To navigate through the different menus, you can use the following keys:

Use the Left and Right cursor arrow keys to choose the pages from the main menu bar across the top of the screen.

Use the Up and Down cursor arrow keys to select the items on each page.

Use the Space bar or the Plus key to cycle forwards through the values that can be installed for each item.

Use the Minus key to cycle backwards through the values that can be installed for each item.

Use the Esc key to display the Exit page of the setup utility.

Use the F9 key to install the items of the setup utility with default values.

Use the F10 key to save the changes and exit the setup utility.

On items marked with a triangular pointer (4), press Enter to display a sub-menu. Press Esc to close the sub-menu and return to the original page.

Main Page

System Time Defines the system time, using the format hour:minute:second (24-hour format). The Tab key moves the cursor, and the Space bar and the Plus and Minus keys change numbers.

System Date Defines the system date. The Tab key moves the cursor, and the Space bar and the Plus and Minus keys change numbers.

Diskette A Always set to 1.44MB,31/2. You cannot change this item.

Diskette B Lets you enable the floppy disk or define it as Not Installed. To use it, set this item to 1.44MB,31/2".

Primary Master Press Enter to display the primary master sub-menu. Type is set to Auto so that the system automatically detects the hard disk drive in your system. Press Esc to return to the Main page.

Secondary Master Press Enter to display the primary master sub-menu. Type is set to Auto so that the system automatically detects the CD-ROM drive in your system. Press Esc to return to the Main page.

Display Device Selection This item determines where the video is displayed when the system is first started. It is recommended to leave this at the default value LCD/CRT.

Resolution Expansion If you enable this item, the system will add extra pixels to screen resolutions that are less than 1024x768 so that they occupy the whole area of the built-in display. Note that resolution expansion causes some distortion of the image on the screen.

PS/2 Mouse Enables or disables the glide pad built into your system.

Boot Options Press Enter to display the Boot Options sub-menu. If Summary screen is Enabled, the system shows a hardware summary at start-up time. If Quiet boot is Enabled, the system displays the Sharp logo screen. Press Esc to return to the Main page.

System Memory Shows the size of conventional memory for starting MS-DOS.

Extended Memory Shows the size of extended memory beyond 1 MB.

Advanced Page

Serial port Sets the RS-232C serial port (only available on the optional Port Replicator), selecting the base I/O address. Enabled means that you can set the item yourself. Auto means that the item is automatically assigned. Disabled means that you cannot use the port.

IrDA port Sets the infrared port, selecting the I/O address and IRQ channel, and the DMA channel. Enabled means that you can set the items yourself. Auto means that all the items except the mode are automatically assigned. Disabled means that you cannot use the port. Set to Auto during normal use.

Parallel port Sets the printer port, selecting the mode, the base I/O address, and the IRQ channel. Enabled means that you can set the items yourself. Auto means the items except the mode are automatically assigned. Disabled means that you cannot use the port.

Mode Specifies the LPT port mode: Bi-directional, ECP (Extended Capabilities Port mode), EPP (Enhanced Parallel Port mode) or Output only. If you set the mode to ECP, you can also select a DMA channel.

Security Page



See Chapter 7 for detailed information on setting passwords in the Security page. Under some password settings, not all items are available to all users.

Set Supervisor Password Defines the supervisor password (up to eight characters).

Set User Password Defines the user password (up to eight characters). You cannot set the user password unless you have set the supervisor password.



If you lose or forget your password while password protection is enabled, you lose access to your computer. Make sure you select a password that you will not forget, or you keep a record of your password in a secure place. Otherwise, you must ask your dealer for assistance.

Password on boot Defines whether the system requires passwords during the boot process. Enabled means that you need to input a password to continue.

Diskette access Specifies who can access the floppy disk drive.

Power Page

Because your computer supports ACPI (Advanced Configuration and Power management Interface), a powerful feature of the Windows 98 operating system, the power management for your system is controlled by the Windows OS and the items on this page have no function. See Chapter 3 for information on using the Windows Power Management Properties program.

If you install your computer with an alternative operating system that does not have ACPI (for example Windows NT 4.0), you can use the items on this page to manage power on your system.

PM Control Lets you enable or disable all the power management, or have it operate when you are using Battery Powered Only.

Power Savings Lets you set Maximum Battery Life (short timeouts for aggressive power management), Maximum Performance (long timeouts for relaxed power management), or Customized (lets you define your own timeout settings using the items below).

Auto Suspend Timeout If you have chosen Customized for the Power Savings item, use this item to set the timeout for suspend mode.

Hard Disk Timeout If you have chosen Customized for the Power Savings item, use this item to set the timeout for a hard disk drive powerdown.

Video Timeout If you have chosen Customized for the Power Savings item, use this item to set the timeout for the built-in display to powerdown.

Battery Low Suspend If you enable this item, the system will automatically enter the suspend mode when battery charge is critically low.

Resume on Modem Ring If you enable this item, the system can resume from suspend mode when an incoming call is received by the modem.



The built-in modem may not be available in some countries.

Resume on Time If you enable this item, the system can resume from suspend mode by an alarm set on the computer's realtime clock.

Resume Time If you have enabled the Resume on Time item, use

this item to set the alarm time.

Cooling Control Use this item to determine how the system controls the thermal management of your system. If you select Performance, the system turns on the cooling fan first when cooling is required. It only throttles the processor if further cooling is required. If you select Silence, the system throttles the processor first when cooling is required. It only turns on the cooling fan if further cooling is required.

Boot Page

The Boot page shows the order of preference your system follows when it seeks an operating system at start-up time. To change the order, highlight an item and then use the Plus and Minus keys to move it up or down the list.

Exit Page

Exit Saving Changes Saves the settings you have changed and exits the Setup Utility.

Exit Discarding Changes Exits the Setup Utility without saving the changes you made during the current session.

Load Setup Defaults Returns the values of all items to default. To exit, select one of the above items.

Discard Changes Returns the values of all items to the values you last saved.

Save Changes Saves the settings you have changed.

CHAPTER 2. SPECIFICATIONS

Parts		Specifications
CPU		Mobile Pentium III Processor (frequency differs by configuration)
Secondary cache		256 KB (Integrated with CPU)
ROM		Including system BIOS and VGA BIOS
RAM	System	SDRAM 64 MB (expandable to 192 MB)
	Video	6 MB
Display	Panel	Active Matrix (TFT) color LCD
	Video controller	NeoMagic NM2380
Keyboard		IBM compatible keyboard
Pointing device		Glide pad (touch-sensitive control pad with 2 buttons)
Drive	Hard disk	IDE interface
	Floppy disk	3.5", 1.44MB/720KB
PC card slot		Type II x 1 (PCMCIA 2.1 compliant) CardBus compliant
Audio system		Monaural microphone, monaural speaker, sound system compliant with AC97
I/O ports	Audio	Headphone jack
	Video	External monitor port
	Others	USB port, modem jack, parallel/FDD port
Infrared		IR port (IrDA:115Kbps/4Mbps)
Modem (may not be available in some countries)		Data: 56Kbps(receive), 33.6Kbps(send), Fax : 14.4Kbps
Power	AC adapter	100-240V, 50-60Hz
	Battery	Rechargeable lithium ion battery
	Battery life	Approximately 2 hours Battery life may vary depending on usage
	Battery charging time	Turned off/suspend mode: about 2 hours Turned on: about 4 hours Charging time may vary depending on usage
Dimensions	Computer	12.04" wide x 9.48" deep x 1.08" high (306mm x 241mm x 27.4mm) 4.58 lbs (2.08 Kg)
	FDD box	5.51" wide x 5.86" deep x 0.59" high 140mm x 149mm x 15mm
Temperature Environment	Operating	50°F to 95°F (10°C to 35°C)
	Humidity	20% to 80% (non-condensation)

Options

AC adapter..... CE-A80V

Battery Pack..... CE-BL08

Floppy Disk Drive Box..... CD-FC01

Port Replicator CE-DS02

(May not be available in some countries)

Design outline of the model PC-A810

[CPU]

Name: Intel® Mobile Pentium II Processor (Coppermine 450MHz)

Specification: Core voltage 1.6 V
32-bit operation, 64-bit data bus, MMX command support
Internal 32 KB-L1 cache/ 256 KB-L2 cache

Package: 495-pin BGA2 package

[Core logic (Northbridge)]

Name: 440BX System Controller Northbridge

Model: Intel 82443BX

Package: 492-pin mBGA

[Core logic (Southbridge)]

Name: PCI-to-ISA / IDE XCELERATOR Southbridge

Model: Intel 82371EB (PIIX4E)

Specification: PCI-ISA, PCI-IDE, USB (2 slots), Power Management controller, Supports SMBus, Fullsupports ACPI Rev.1.0

Package: 324-pin mBGA

[System memory configuration]

Capacity: 64 MB (on-board) as standard; up to 192 MB (when one 128 MB DIMM is installed into the SO-DIMM slot)

SD-RAM to be used: 128 Mbit SD-RAM (4M x 2 banks x 16 bits)

Slot specification: 3.3 V, 144 pins, 8-byte SO-DIMM
SDRAM specification:
supports 1 ~ 1.5 inch H
Supports 1 bank/2banks per slot.

[BIOS]

Name: 512 KB, flash E2PROM (SST28SF040)

Specification: System BIOS, VGA-BIOS and keyboard BIOS are built in.

Architecture: Connection through keyboard controller (not directly connected to ISA bus.)

Package: 32-pin QFP

[Display]

Name: 13.3" XGA (1024 x 768) thin TFT panel

Model: SHARP LQ133X1LS20

Specification: AGLR (anti-glare hard coat/low reflection) surface treatment
262,144 colors (6 bits for each color) and up to 16,777,216 colors are displayable in a pseudo manner by dithering.
LVDS interface

[Inverter for backlight]

Name: Inverter for single lamp

[Display controller]

Model: NeoMagic MN2380

Specification: PCI bus connection, ZV support, PC97 compatible

Video memory: Embedded (built-in) video memory, SG-RAM 6 MB

Displayable colors:

LCD,	16M colors	(1024 x 768, 800 x 600, 640 x 480)
CRT,	256 colors	(1280x1024, 1024x768, 800x600, 640x480)
	64 K colors	(1280 x 1024, 1024x768, 800x600, 640x480)
	16 M colors	(1024x768, 800x600, 640x480)
Simultaneous,	64 K colors	(1024x768, 800x600, 640x480)
	16 M colors	(1024 x 768, 800 x 600, 640 x 480)

Package: 329-pin BGA

[I/O controller]

Name: ISA connection, Super I/O

Model: National Semiconductor PC97338VJG

Specification: FDD interface, serial interface
IR interface (IrDA [SIR-115K, FIR-4M])
Parallel interface (ECP/EPP compatible)

Package: 100-pinTQFP

[HDD]

Name: IDE connection, 2.5 inch

Model: Toshiba MK8113

Specification: 8.1 GB (8.5 mm H)

[FDD]

Name: 3.5-inch, 3-mode floppy disk drive

Model: Citizen WiDE-31B

Specification: Supports 1.44 MB, 1.2 MB, 720 KB
Installable to a PC bay exclusively together with CD-ROM/ to be supplied with the PC.

[CD-ROM]

Name: IDE connection, 9.5 mm H CD-ROM drive

Model: Matsushita CR-271-d

Specification: Up to x24 speed
Installable to a PC bay exclusively together with the FD drive./ to be supplied with the PC.

[PCMCIA controller]

Model: Texas Instrument PCI1211

Specification: PCI connection, Cardbus support
ACPI rev. 1.0 support

Package: 208-pin TQFP

[Keyboard/mouse controller/embedded controller]

Name: ISA bus connection, single chip 8-bit microprocessor

Model: National Semiconductor NS87570

Specification: PS/2 interface, 3 ports
Internal and external keyboards can be used simultaneously.
Internal touch pad and external mouse can be used simultaneously.
SMBus interface
Power management GPIO/SCI generation
BIOS ROM interface

Package: 176-pin QFP

[Power management ASIC]

Function: Event monitoring (LCD opening and closing, the insertion of device into bay, the insertion of HDD, detection of port dock) and VGA controller reset control in the suspend mode.

[Keyboard]

Specification: US keyboard, 85 keys, 19-mm key pitch/2.5-mm key stroke

[Pointing device]

Name: Wheel function support touch pad

Model: LOGITEC TP3

Specification: PS/2 mouse interface support (3 buttons/wheel function support)

[Audio]

Sound chip: Internal NeoMagic NM2380, PCI connection
ACPI Rev. 1.0 support, PC97 support

Codec: STAC9704 that conforms AC97

Amplifier: TPA0103 headphone/speaker amplifier

Specification: Internal monaural microphone and monaural speaker that are controlled by hot keys about volume.

[FAX/MODEM]

Name: PCI connection, 56 Kbps Data/ 14.4 Kbps FAX
PCtel soft modem

Model: V1456VQL14N (developed by ASKEY Taiwan)

Specification: K56 flex, V,90 support
Fax transmitting and receiving speed, 14.4 Kbps
Data transmitting and receiving speed, 56 Kbps (for transmission)/ 33.6 Kbps (for receiving)

Destination: U only

[I/O port]

Parallel/external FDD port (D-sub: 25-pin female) x1
CRT port (shrink D-sub: 15-pin female) x1
Phone-out port (stereo mini: jack) x1
PCMCIA card slot: Type II x1
IR port x1
AC adapter jack x1
Kensington Lock Hole x1
Modem port (modular jack) x1
144-pin SO-DIMM expansion memory slot x1 (1.5 inch height support)
USB port x1
Port dock connector x1

[Battery unit]

Name: LI-ION battery unit (CE-BL08)

Specification: SANYO 10.8 V/2800 mAh, 30 W (3.6 V/1400 mAh cell x 2 parallel, 3 serial)
Directly rechargeable through an AC adapter separately.

[Backup]

Content: Clock, calendar, CMOS setting backup

Power supply: 7.2 V 15mAh Ni-MH secondary battery pack, 1 pc. (VARTA)

Installation: Taped to the lower cabinet with double-coated tape.

[AC adapter]

Name: 50W AC adapter(CE-A80V)

Specification: Input: 100~240V, 50/60Hz, 1.5A
Output: 50W - 19V/2.64A

[Indicator]

Type (LED)	Condition	Action
Power LED	Power OFF	Off
	AC/battery operation	Green light
	Suspend to RAM mode	Green light blinks
Battery status LED	No battery installed	Off
	During charge	Orange light
	Charge completed	Green light
	Low battery voltage	Red light
	Very low battery voltage	Red light blinks
CD-ROM Access LED	CD-ROM being accessed	Green light
HDD Access LED	HDD being accessed	Green light
FDD Access LED	FDD being accessed	Green light
Numlock LED	Numlock selected	Green light
CAPS lock LED	Caps lock selected	Green light
Scroll Lock LED	Scroll lock selected	Green light

CHAPTER 3. ASSEMBLY AND DISASSEMBLY

1. Subsystem Overview

The Notebook Subsystems include the following:

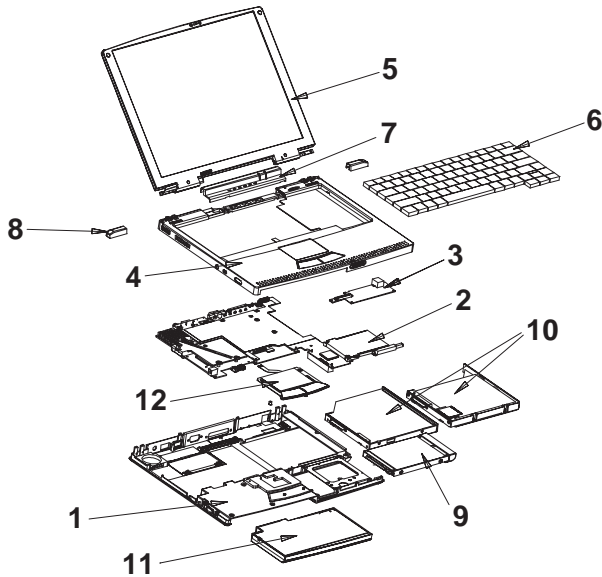

- | | |
|--------------------|------------------|
| 1. Base Assembly | 2. PCB assembly |
| 3. Modem Board | 4. Top Assembly |
| 5. LCD Module | 6. Keyboard |
| 7. Middle Cover | 8. Hinge Covers |
| 9. HDD Module | 10. CDROM Module |
| 11. Battery Module | 12. Touch Pad |

2. Removing RAM Module

1. Put the system unit bottom side up.
2. Remove the RAM module cover.
3. Remove the RAM module.

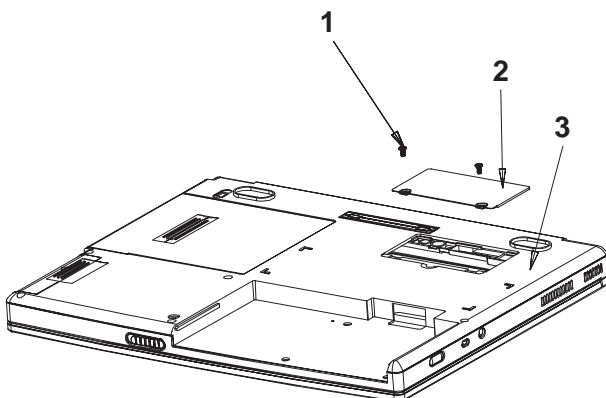

1. RAM Door Screws (M2.6 x 2.5)
2. RAM Door
3. Main Unit

3. Removing Battery Pack

1. Push the latch knob on the left side.
2. Hold and then slide the battery pack towards to take it out.
3. Raise and remove the battery pack.

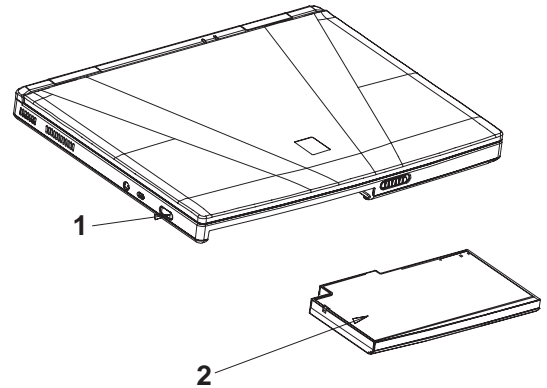

1. Battery Release Button
2. Battery Module

4. Removing CDROM Module

1. Put the system unit bottom side up. Locate the CDROM drive pack.
2. Slide the CDROM/FDD pack latch knob outwards. Hold and then slide the CDROM pack out.
3. Raise and remove the CDROM pack.

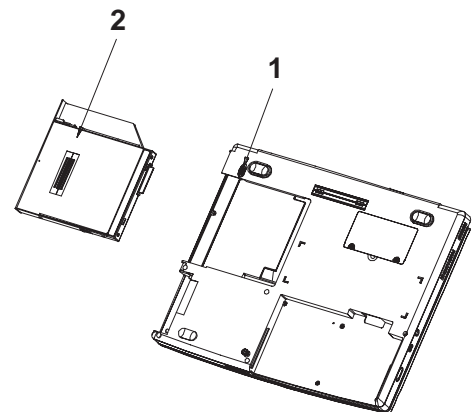

1. CDROM/FDD Release Knob
2. CDROM Module

5. Removing FDD Module (Same as CDROM)

1. Put the system unit bottom side up. Locate the FDD drive.
2. Slide the CD-ROM/FDD pack latch knob outwards. Hold and then slide the FDD pack out.
3. Raise and remove the FDD pack.

6. Removing HDD Module

1. Put the system unit bottom side up. Locate the HDD.
2. Unscrew the HDD assembly mounting screws.
3. Slide the HDD pack out from the HDD tray.
4. Disassemble the HDD assembly.

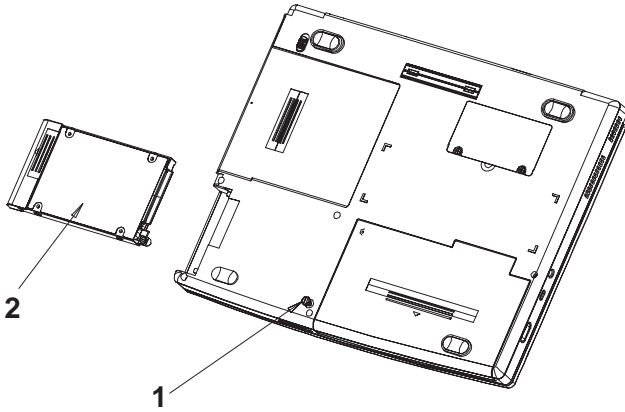

1. HDD Screw (M2.6 x 6.3)
2. HDD Module

7. Removing LCD Module

1. Open the LCD and remove two hinge covers.
2. Unscrew and remove four screws on hinge and two screws of middle cover on the rear side.
3. Push middle upwards and take it out from main unit.
4. Take out inverter and LCD cables.
5. Raise the LCD module and remove it.

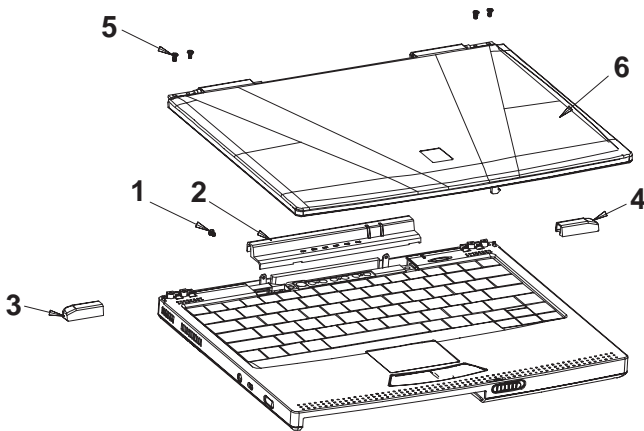

1. Middle Cover Screws (M2.6 x 5)
2. Middle cover
3. Hinge Cover - L
4. Hinge Cover - R
5. Hinge Screws (M2.6 x 5)
6. LCD Module

8. Removing Top Assembly

1. Unscrew and remove two screws between top and keyboard.
2. Disconnect the keyboard and remove it.
3. Disconnect the glide pad and remove it.
4. Put the system unit bottom side up.
5. Unscrew and remove those nine top mounting screws
6. Put the system unit top side up and remove the top assembly.

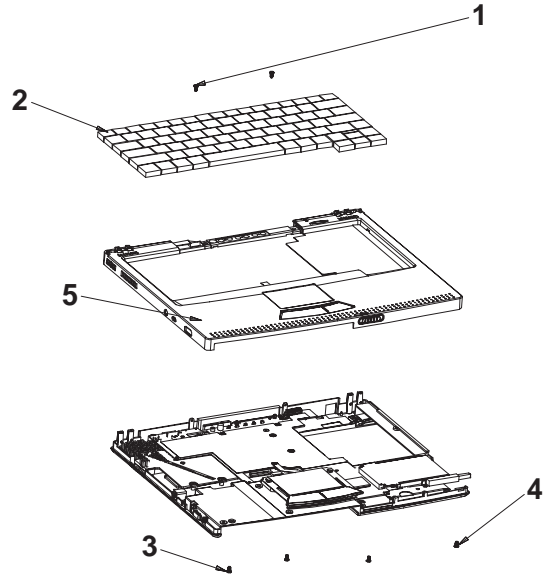

1. Keyboard Screws (M2.6 x 2.5)
2. Keyboard
3. Base Cover Screws (M2.6 x 4)
4. Base Cover Screw (M2.6 x 5)
5. Top

9. Removing Glide Pad Module

1. Unscrew and remove two screws on glide pad.
2. Raise the glide pad module and remove it.

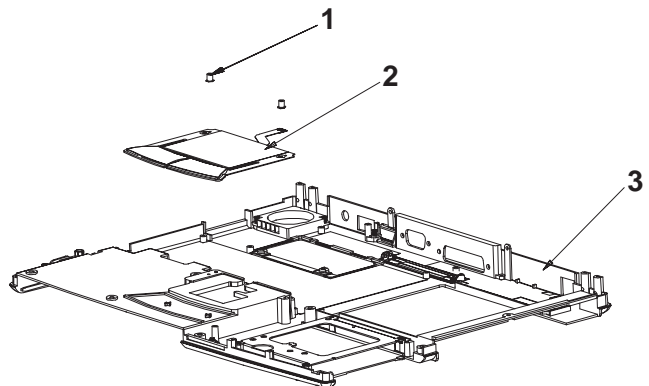

1. Touch Pad Screws
2. Touch Pad
3. Base Unit

10. Removing PCMCIA Ejector Module

1. Unscrew and remove two screws between PCMCIA ejector and upper board.
2. Unscrew and remove two screws between PCMCIA ejector and PCMCIA bracket.
3. Raise the PCMCIA ejector and remove it.

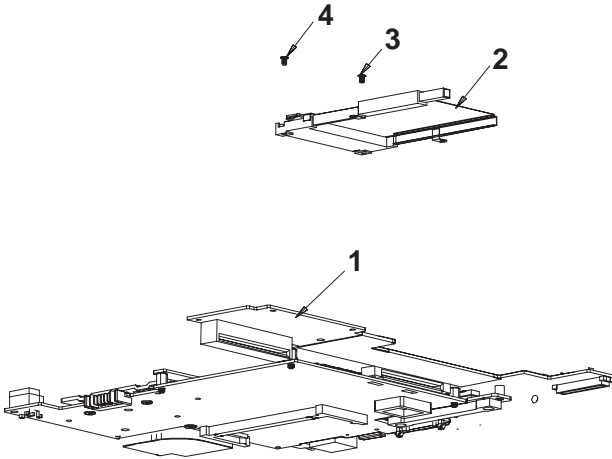

- | | |
|-----------------------------|-----------------------------|
| 1. Upper Board | 2. PCMCIA Ejector |
| 3. Ejector Screw (M2.0 x 3) | 4. Ejector Screw (M2.0 x 4) |

11. Removing Upper, and Modem Board from Main Board

1. Remove speaker, RTC battery, fan and switch board cables.
2. Unscrew and remove five screws on upper board.
3. Unscrew and remove two screws between modem board and base cover.
4. Unscrew and remove two nuts between printer port and base cover.
5. Remove copper foil on heat sink and upper board.
6. Raise and remove the upper board and modem board.

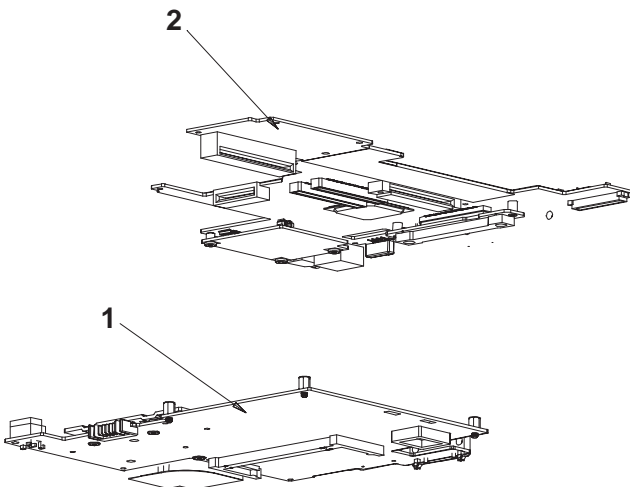

- | |
|----------------|
| 1. Main Board |
| 2. Upper Board |

12. Removing Modem Board from Upper Board

1. Unscrew and remove three screws between audio board and upper board
2. Raise the modem board and remove it.

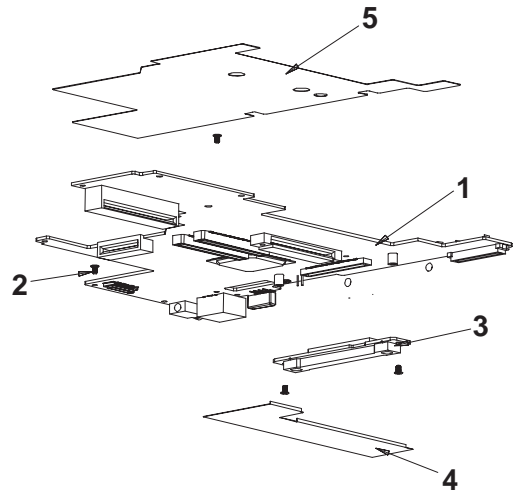

- | |
|-------------------------------------|
| 1. Upper Board |
| 2. Low Deck Board Screws (M2.0 x 3) |
| 3. Lower Deck ASSEMBLY |
| 4. UB MYLAR (1) |
| 5. UB MYLAR (2) |

13. Removing Heat Sink Module

1. Unscrew and remove two screws between heat sink and system board.
2. Unscrew and remove one screw between heat sink and base cover.
3. Raise the heat sink and remove it.

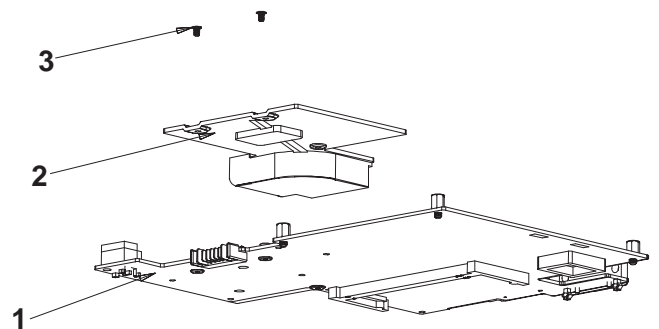

- | |
|--------------------------------|
| 1. Main Board |
| 2. Heat Sink |
| 3. Heat Sink Screws (M2.0 x 3) |

14. Removing Main Board

1. Unscrew and remove two nuts between CRT port and base cover.
2. Unscrew and remove five screws on system board.
3. Raise the system board and remove it

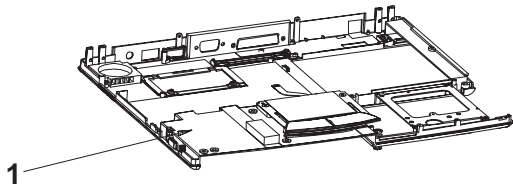
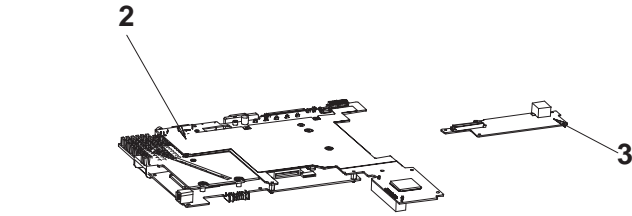

1. Base
2. Main Board
3. Modem Board

15. Base Sub-Assembly

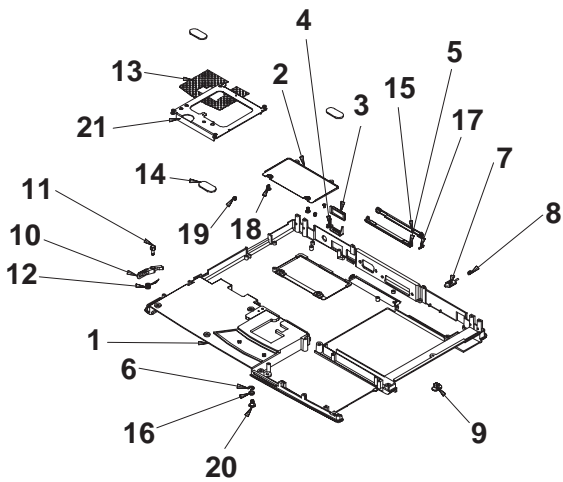
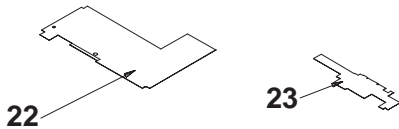

1. Base
2. RAM Door
3. IR Lens
4. IR Lens holder
5. Dock Door (F)
6. HDD Spring
7. CDROM/FDD Module Slider
8. CDROM/FDD Module Knob Spring
9. CDROM/FDD Module Knob

10. Battery Knob
11. Battery Nut
12. Battery Knob Spring
13. Touch Pad Mylar
14. Rubber Foot
15. Dock Door (B)
16. E-Fastener
17. Dock Door Spring
18. RAM Door Screws (M2.6 x 2.5)
19. Screw (M2 x 3)
20. Screw (M2.6 x 6.3)
21. PCMCIA Bracket
22. Base Mylar (1)
23. Base Mylar (2)

16. Top Sub-Assembly

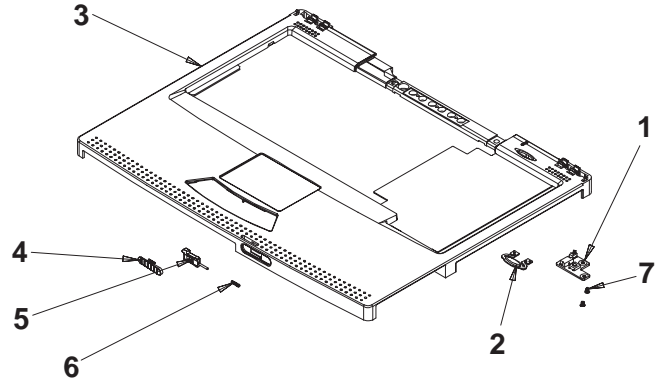

1. Switch Board
2. Power Switch Knob
3. TOP
4. Hook Knob
5. Hook Knob Slider
6. Slider Spring
7. Switch Board Screws (M2 x 3)

17. HDD Module Sub-Assembly

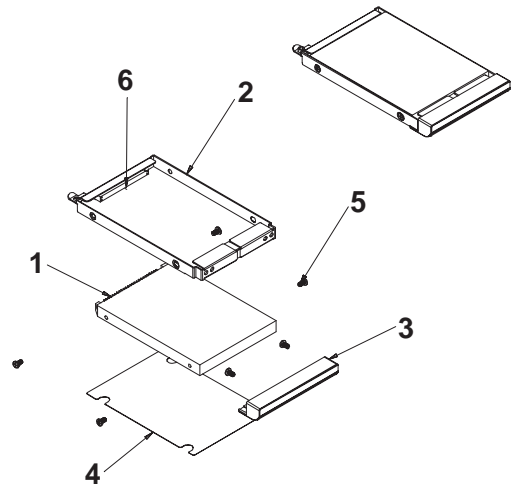

1. HDD (8GB)
2. HDD Frame
3. HDD Bezel
4. HDD Bottom Mylar
5. HDD Connector
6. HDD Screws (M3 x 2.8)

18. FDD Module Sub-Assembly

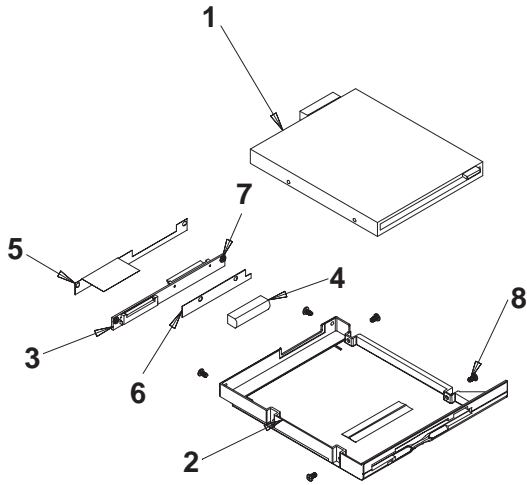

- 1. FDD Drive
- 2. FDD Case
- 3. FDD Board
- 4. FDD Cushion
- 5. FDD Mylar
- 6. FDD Board Mylar
- 7. FDD FPC
- 8. FDD Case Screws (M2.5 x 3)

19. CDROM Module Sub-Assembly

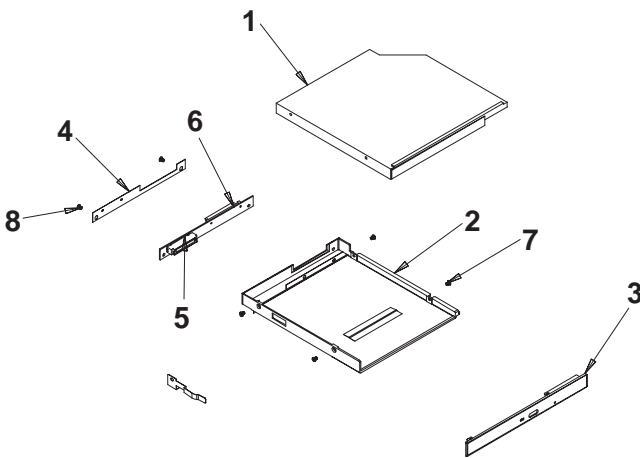

- 1. CDROM Drive 24X
- 2. CDROM Case
- 3. CDROM Panel
- 4. CDROM Mylar
- 5. CDROM Mylar (F)
- 6. CDROM Board
- 7. CDROM Screws (M2 x 2.5)
- 8. CDROM Board Screws (M2.0 x 4)
- 9. CDROM EMI Spring

20. Battery Module Sub-Assembly

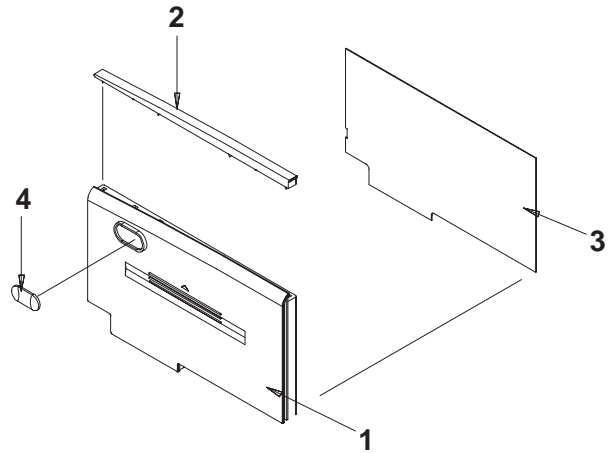

- 1. Complete Battery Pack
- 2. Battery Bezel
- 3. Battery Mylar
- 4. Rubber Foot

21. LCD Module Sub-Assembly

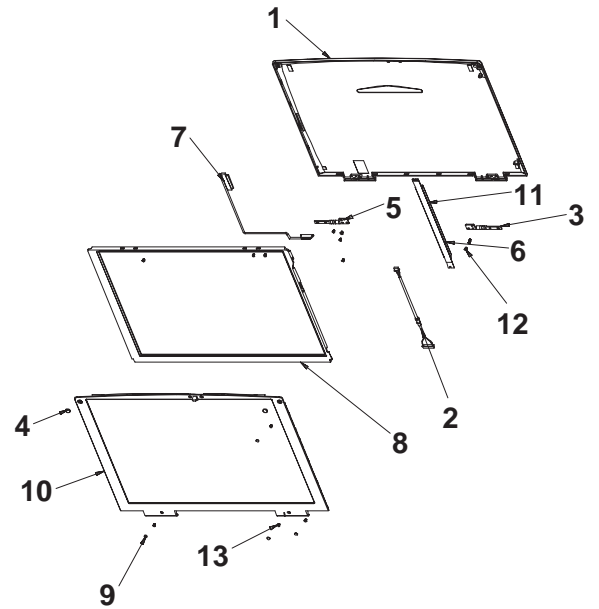

- 1. LCD Cover
- 2. Inverter Cable
- 3. Hinge®
- 4. Rubber (1)
- 5. Hinge (L)
- 6. Inverter Mylar
- 7. LCD Cable
- 8. LCD
- 9. Rubber (2)
- 10. LCD Bezel
- 11. Inverter Module
- 12. Screws (M2 x 4)
- 13. Screw (M2 x 3)

CHAPTER 4. PRECAUTIONS

(1) Small fan

- Do not touch, press, or rotate the rotor (fan).
- Do not drop the fan (never use the fan if dropped by mistake).
- Do not hit the fan with another fan. (Avoid collisions between the fans).
- Do not hit any object (part) with the fan.
- Do not hold the lead wire.
- Do not pull the lead wire.
- When you bring the fan, put it in the original box used when delivered from the manufacturer.
- Do not pile up the fans.
- Do not place the fan with the rotor part down. (rotor may be stressed due to its structure)
- When you set up the fan on other machinery part, do it without giving stress to the rotor.
- When you handle the fan, place an air cap, etc. on the work table before you set to work.

If the fan is subjected to any physical shock, the bearing may crack, a rotation noise is generated and the crack will grow greater which may result in trouble with rotation. Therefore, be sure not to use it even if it seems to function normally.

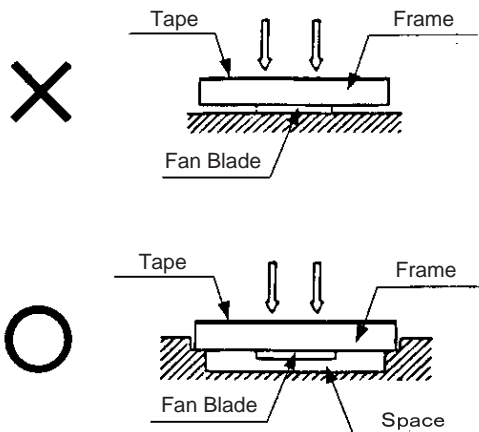
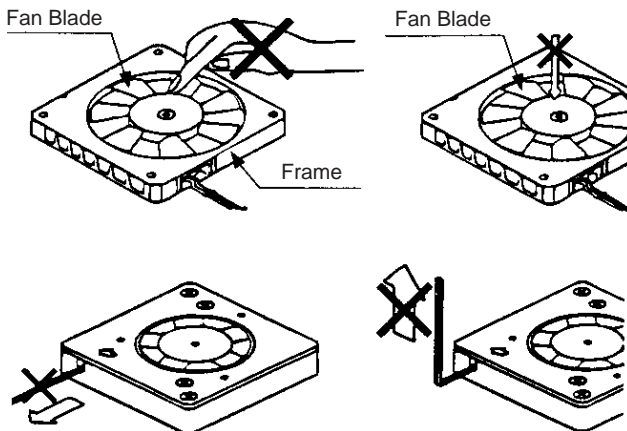

(2) FDD/HDD/CD-ROM

(Precautions when unpacking the package)

1. Be careful not to expose unit to any physical shock since it is a precision instrument. (do not give it a shock equivalent to or exceeding a drop from the height of 70 cm in a packed condition)
2. Be sure workers and their cloths are not charged with electricity when they handle the parts. (be sure they wear a grounding band)
3. Packing must be done under the following conditions: (same conditions apply to the assembling)

Temperature (°C)	Humidity (% RH)	Temperature change (°C/H)
10 ~ 40	20 ~ 80	20

* When the temperature is low, do not forget to take measures against static electricity.

* Temperature change means the difference in temperature between before and after the unpacking.

4. Be sure not to pile up precision instruments by themselves, but to place each of them on a stable and non-shocking underlay. (be sure to keep the board surface down)

(Storage)

◆ Storage method common in servicing and in packed condition

1. Be sure to store it in the following conditions:

Temperature (°C)	Humidity (% RH)
-16 ~ 60	20 ~ 80

* Do not store in a car in summer.

* When the temperature is low, do not forget to take measures against static electricity.

◆ Storage method in servicing

1. When parts are stored alone, they should be covered. (be sure to take measures against dust)
2. Be sure to take measures against static electricity. (Place the part on a mat which prevent static electricity)
3. Do not pile up the parts. (also be sure not place any other part on a part)

◆ Storage method in packed condition

1. Regardless of the length of the storage period, store it in the same condition as it is originally packed and delivered.

(Handling)

1. Do not forget to wear a grounding band when working on unit.

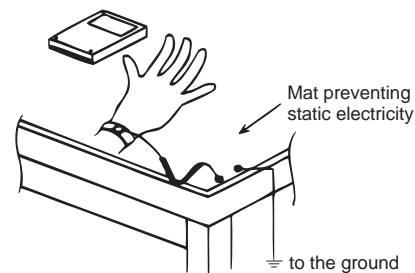

* Confirm with a tester when you put the grounding band (1MΩ ~ 10MΩ) on. A grounding wire should be installed at an appropriate location.

2. For any unit, do not stack in piles.

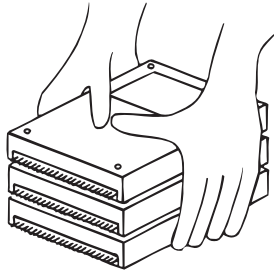

3. Avoid any impact with the unit.

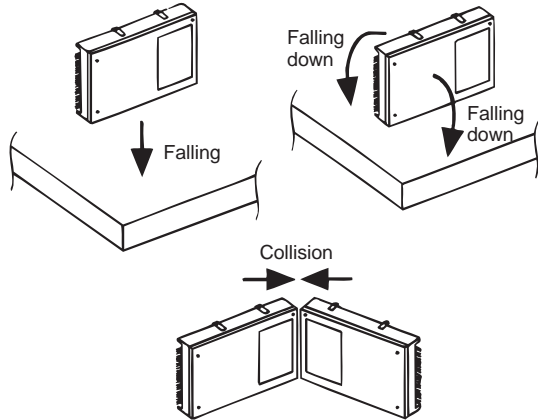

* Be sure not to use the unit(s) if they were subject to any physical shock.

4. Hold the units by the side.

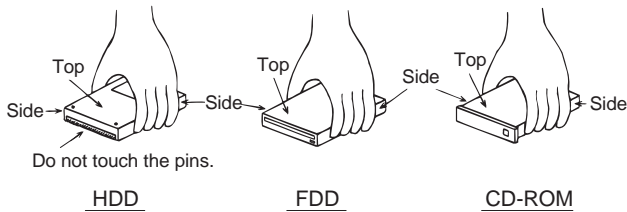

5. Use designated torque/tools (low impact drivers)

6. Keep magnetic materials away from the unit.

Precaution when handling FDD

1. Do not press the top surface of FDD.

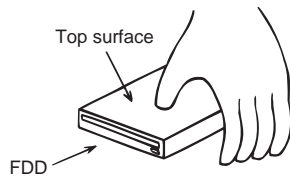

Precautions when handling CD-ROM drive

1. Be sure not to touch the object lens.
2. Be sure to keep dust and dirt away from the object lens.

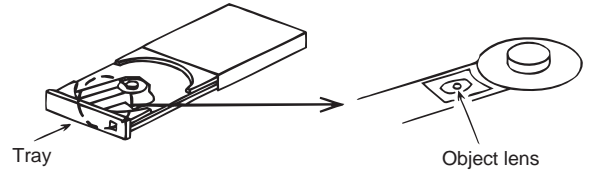

* If the object lens is stained with dust and/or dirt, remove them with one of the following methods:

- Blow the dust with an airgun.
- Use Hitachi-Maxell's CD-ROM lens cleaner.
- Wipe the lens gently with an applicator using Nippon Applicators' CD lens cleaner liquid B4.

3. Do not press the top surface of CD-ROM drive.

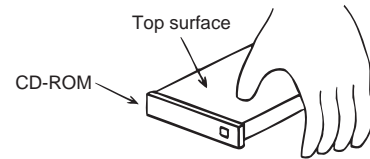

4. Do not pull the tray by force.
5. Do not apply any upward, downward, left or right force to the tray.
6. Be sure to insert a CD-ROM by pressing it in the middle.

Precaution on HDD

1. Cable connection/disconnection and transfer of HDD shall be performed after the unit is left untouched for more than 15 seconds after the power supply is turned off (a state where the motor of HDD has been stopped or green/red light has been on).

CHAPTER 5. RE-INSTALLATION

Using the Recovery CD

If your hard disk drive ever gets corrupted, for example by a computer virus, you can use the recovery CD to return the state of your hard disk to the way it was when your computer shipped from the factory. Of course, you will lose any data that you created and stored on your hard disk drive when you use the recovery CD, therefore we recommend that you always keep up-to-date backups of important data on separate media.



Using the Recovery CD deletes all the software and data on your hard disk drive and returns your drive to its original state, with just the Windows 98 operating system and the supplied software and drivers. If you don't have backups of the data and software that you have installed on the hard disk, you cannot restore them after using the recovery CD.

Before you begin, make sure that the drive bay on the right side of the computer is installed with the CD-ROM drive module. Make sure that you have the Windows product key (identification number) that was supplied with your computer. You typed in the Windows product key when you carried out the Windows Setup Wizard program in Chapter 1.

1. Connect your computer to a power outlet with the AC adapter.



Do not attempt to use the recovery CD with the computer running on battery power. The recovery process takes some time and it is important that the process is not interrupted by loss of power.

2. Turn on your computer and at the Sharp logo and setup prompt, press F2 to run the setup utility.
3. In the setup utility, open the Boot page and make the CD-ROM the first boot location. See Boot Page in Chapter 8 for more information.
4. Insert the recovery CD into the CD-ROM.
5. Exit the setup utility saving changes.
6. When your computer restarts it boots the recovery program from the recovery CD.
7. The opening screen explains the recovery procedure and asks if you want to continue. Press Enter to continue, press Esc to cancel.
8. The second screen asks you to disconnect all peripheral devices from the computer. If you do have peripheral items connected, press Esc to cancel, turn off your computer, remove the devices and start again. Press Enter to continue.
9. The third screen reminds you that the recovery process destroys all data on the hard disk drive. Type Y to continue, or type N to cancel.
10. The recovery process begins automatically and onscreen arrows and slider bars let you track the progress of the procedure. It takes about 10 to 15 minutes to fully recover the hard disk drive.
11. When the recovery is complete, a prompt appears asking you to remove the recovery CD-ROM from the CD-ROM drive and to press any key to restart your computer.
12. When your computer restarts, you might like to run the setup utility once again and change the boot priority in the Boot page back to its usual setting.

13. Windows may have to re-install some software or drivers. Follow the screen prompts of the Add New Hardware Wizards as they appear. Your computer may have to restart after the new drivers are installed.
14. When your computer restarts, you are presented with the Windows Setup Wizard program that is described in Chapter 1. Follow the steps of the program and your hard disk recovery is complete.

CHAPTER 6. MAIN BOARD CONNECTOR INFORMATION

1. Expansion Memory Connector

Pin	Description	Pin	Description	Pin	Description
1	GND	2	GND	3	MD0
4	MD32	5	MD1	6	MD33
7	MD2	8	MD34	9	MD3
10	MD35	11	+3VSUS	12	+3VSUS
13	MD4	14	MD36	15	MD5
16	MD37	17	MD6	18	MD38
19	MD7	20	MD39	21	GND
22	GND	23	DQMA0	24	DQMA4
25	DQMA1	26	DQMA5	27	+3VSUS
28	+3VSUS	29	MA0	30	MA3
31	MA1	32	MA4	33	MA2
34	MA5	35	GND	36	GND
37	MD8	38	MD40	39	MD9
40	MD41	41	MD10	42	MD42
43	MD11	44	MD43	45	+3VSUS
46	+3VSUS	47	MD12	48	MD44
49	MD13	50	MD45	51	MD14
52	MD46	53	MD15	54	MD47
55	GND	56	GND	57	N.C.
58	N.C.	59	N.C.	60	N.C.
61	CLK_SDRAM1	62	CKE1	63	+3VSUS
64	+3VSUS	65	SRASB#	66	SCASB#
67	MWEB#	68	CKE1	69	CSA#1
70	MA12	71	CSA#2	72	MA13
73	GND	74	CLK_SDRAM2	75	GND
76	GND	77	N.C.	78	N.C.
79	N.C.	80	N.C.	81	+3VSUS
82	+3VSUS	83	MD16	84	MD48
85	MD17	86	MD49	87	MD18
88	MD50	89	MD19	90	MD51
91	GND	92	GND	93	MD20
94	MD52	95	MD21	96	MD53
97	MD22	98	MD54	99	MD23
100	MD55	101	+3VSUS	102	+3VSUS
103	MA6	104	MA7	105	MA8
106	MA11	107	GND	108	GND
109	MA9	110	MA12	111	MA10
112	MA13	113	+3VSUS	114	+3VSUS
115	DQMA2	116	DQMA6	117	DQMA3
118	DQMA7	119	GND	120	GND
121	MD24	122	MD56	123	MD25
124	MD57	125	MD26	126	MD58

Pin	Description	Pin	Description	Pin	Description
127	MD27	128	MD59	129	+3VSUS
130	+3VSUS	131	MD28	132	MD60
133	MD29	134	MD61	135	MD30
136	MD62	137	MD31	138	MD63
139	GND	140	GND	141	PDATA_SMB
142	PCLK_SMB	143	+3VSUS	144	+3VSUS



2. HDD Connector

Pin	Description	Pin	Description	Pin	Description
1	BRSTDRV#	2	GND	3	PIDED7
4	PIDED8	5	PIDED6	6	PIDED9
7	PIDED5	8	PIDED10	9	PIDED4
10	PIDED11	11	PIDED3	12	PIDED12
13	PIDED2	14	PIDED13	15	PIDED1
16	PIDED14	17	PIDED0	18	PIDED15
19	GND	20	N.C.	21	PIDEREQ
22	HDDINS#	23	PIDEIOW#	24	GND
25	PIDEIOR#	26	GND	27	PDIORDY
28	PULL-LOW	29	PIDEDACK#	30	GND
31	IRQ14	32	N.C.	33	PIDEA1
34	PULL-UP	35	PIDEA0	36	PIDEA2
37	PIDECS1#	38	PIDECS3#	39	HDDLED#
40	GND	41	+5VRUN	42	+5VRUN
43	GND	44	PULL-UP		

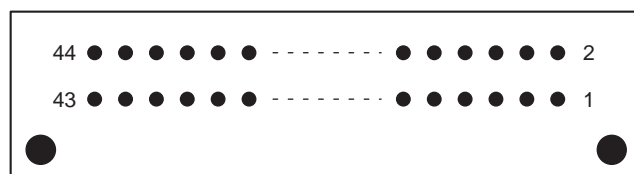

3. D_SUB Connector

Printer Port

Pin	Description	Pin	Description	Pin	Description
1	STRB#	2	LPD0	3	LPD1
4	LPD2	5	LPD3	6	LPD4
7	LPD5	8	LPD6	9	LPD7
10	PACK#	11	PBUSY	12	PPE
13	PSLCT	14	LAFD#	15	LERROR#
16	LINIT#	17	PSLIN#	18	GND
19	GND	20	GND	21	GND
22	GND	23	Pull-Up	24	PNF#
25	GND				

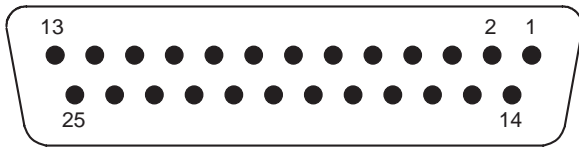

VGA Port

Pin	Description	Pin	Description	Pin	Description
1	R	2	G	3	B
4	N.C.	5	GND	6	GND
7	GND	8	GND	9	VCC
10	GND	11	CRTSENSE	12	DDC2BD
13	HSYNC	14	VSYSN	15	DDC2BC

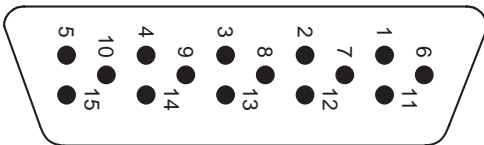

4. PCMCIA Connector

Pin	Description	Pin	Description	Pin	Description
1	GND	2	D3	3	D4
4	D5	5	D6	6	D7
7	CE1#	8	A10_HREF	9	OE#
10	A11_VS	11	A9_Y0	12	A8_Y2
13	A13_Y4	14	A14_Y6	15	WE#
16	RDY#	17	VCCCB	18	VPPCB
19	A16_UV2	20	A15_UV4	21	A12_UV6
22	A7_ISCK	23	A6_IMCK	24	A5
25	A4	26	A3	27	A2
28	A1	29	A0	30	D0
31	D1	32	D2	33	WP_PCLK
34	GND	35	GND	36	CD1#
37	D11	38	D12	39	D13
40	D14	41	D15	42	CE2#
43	VS1	44	IORD#	45	IOWR#
46	A17_A1	47	A18_A3	48	A19_Y5
49	A20_Y7	50	A21_UV0	51	VCCCB
52	VPPCB	53	A22_UV1	54	A23_UV3
55	A24_UV5	56	A25_UV7	57	VS2
58	RST	59	WAIT#	60	INPK#ILR
61	REG#	62	B2/SPK_IDAT	63	BVD1
64	D8	65	D9	66	D10
67	CD2#	68	GND	69	GND
70	GND	71	GND	72	GND
73	GND	74	GND		

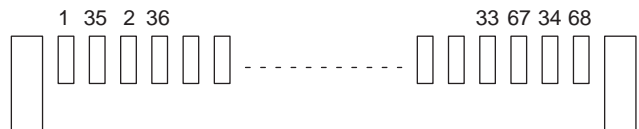

5. CDROM Connector

Pin	Description	Pin	Description	Pin	Description
1	+5VRUN	2	+5VRUN	3	+5VRUN
4	+5VRUN	5	+5VRUN	6	DEVLED#
7	INDEX#	8	DRV0#	9	DSKCHG#
10	GND	11	MTR0#	12	DIR#
13	3MODE#	14	STEP#	15	WDATA#
16	WGATE#	17	TRK0#	18	HEAD#
19	DEVINS#	20	WP#	21	RDATA#
22	GND	23	GND	24	N.C.
25	PDIAG#	26	CDSMI#	27	SIDEC3#
28	SIDEC3#	29	SIDEA2	30	SIDEA1
31	SIDEA0	32	SIDEDREQ	33	SIDEDACK#
34	SDIORDY	35	SIDEIOR#	36	SIDEIOW#
37	GND	38	GND	39	SIDED15
40	SIDED0	41	SIDED14	42	SIDED1
43	SIDED13	44	SIDED2	45	SIDED12
46	SIDED3	47	SIDED11	48	SIDED4
49	SIDED10	50	SIDED5	51	SIDED9
52	SIDED6	53	SIDED8	54	SIDED7
55	IRQ15	56	CDRST#	57	GND
58	CDR	59	CDGND	60	CDL

Pin	Description	Pin	Description	Pin	Description
43	AD20	44	AD17	45	AD22
46	AD19	47	AD24	48	AD21
49	AD26	50	AD23	51	AD28
52	CBE#3	53	AD30	54	AD25
55	GNT#3	56	AD27	57	PCIRST#
58	AD29	59	AD22	60	AD31
61	PIRQC#	62	REQ#3	63	+5VSUS
64	CLKRUN#	65	OHRCN	66	GND
67	GND	68	PCL_MOD	69	+3VSUS
70	PDAT_SMB	71	PCLK_SMB	72	+3VRUN
73	+3VRUN	74	+3VRUN	75	+3VRUN
6	PME#	77	+5VRUN	78	+3VSUS
79	+5VRUN	80	+5VSUS		

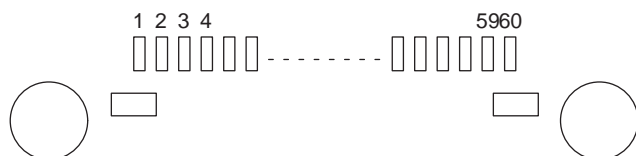
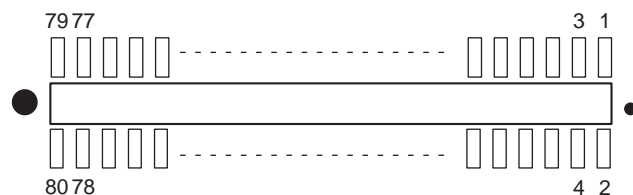

6. Modem Module Connector

Pin	Description	Pin	Description	Pin	Description
1	LWDKIN	2	TXP	3	RIDETN
4	TXN	5	MODEM_SPK	6	INTMIC
7	GND	8	M_RI	9	ILIMITN
10	GND	11	GND	12	GND
13	AD0	14	AD1	15	AD2
16	AD3	17	AD4	18	AD5
19	AD6	20	AD7	21	CBE#0
22	AD8	23	AD9	24	AD10
25	AD11	26	AD12	27	AD13
28	AD14	29	AD15	30	CBE#1
31	PAR	32	SERR#	33	STOP#
34	PERR#	35	TRDY#	36	PLOCK#
37	FRAME#	38	DEVSEL#	39	AD16
40	IRDY#	41	AD18	42	CBE#2

7. Keyboard Connector

Pin	Description	Pin	Description	Pin	Description	Pin	Description
30	MY15	29	N.C.	28	MY13	27	N.C.
26	MY12	25	N.C.	24	MY0	23	N.C.
22	MY2	21	N.C.	20	MY11	19	N.C.
18	MY14	17	MX2	16	MY10	15	MX4
14	MY9	13	MX1	12	MY8	11	MX7
10	MY7	9	MX3	8	MY6	7	MX0
6	MY5	5	MX6	4	MY3	3	MX5
2	MY1	1	MY4				

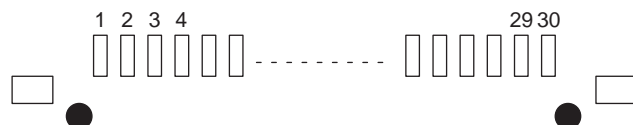

8. USB Connector

Pin	Description	Pin	Description	Pin	Description
1	VCC	2	USBP0-	3	USBP0+
4	GND				

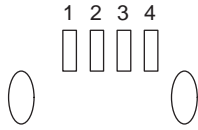

9. Audio jack

Pin	Description	Pin	Description	Pin	Description
1	GND	2	HP_L	3	HP_R
4	GND	5	HP_INS	6	GND

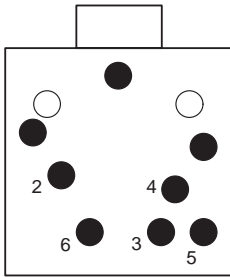

10. Docking Connector

Pin	Description	Pin	Description	Pin	Description
1	GND	2	CD#	3	GND
4	DOCSENSE#	5	DOC_BITCLK	6	DOC_SYNC
7	DOC_SDATAI	8	DOC_SDATAI	9	DOC_RESET#
10	GND	11	GND	12	DIRRX1
13	DIRRX2	14	DIRTX	15	GND
16	R	17	G	18	B
19	GND	20	MSDATA	21	KPDATA
22	RI1#	23	CTS1#	24	RTS1#
25	DSR1#	26	SERRI#	27	PD0
28	GND	29	PD1	30	PD2
31	PD3	32	PD5	33	PD7
34	BUSY	35	+5VRUN	36	+5VRUN
37	+5VRUN	38	+5VRUN	39	+5VRUN
40	+5VRUN	41	Test pad	42	GND
43	STRB#	44	STRB#	45	+3VSUS
46	+3VSUS	47	Test pad	48	VA
49	VA	50	VA	51	GND
52	MUTE	53	OC0#	54	GND
55	GND	56	USBP0+	57	USBP0-
58	GND	59	USBP1+	60	USBP1-
61	GND	62	OC1#	63	CRTSENSE#
64	HSYNC	65	VSYNC	66	DDC_DATA
67	DDC_CLK	68	GND	69	MSCLK

Pin	Description	Pin	Description	Pin	Description
70	KPCLK	71	DTR1#	72	TXD1
73	RXD1	74	DCD1#	75	AFD#
76	ERROR#	77	PINIT#	78	GND
79	SLIN#	80	PD4	81	PD6
82	ACK#	83	PNF#	84	GND
85	PE	86	SLCT	87	Test pad
88	OHRCN	89	RIDETN	90	ILIMITN
91	TXN	92	TXP	93	GND
94	LWDKIN#	95	CD#	96	Test pad
97	Test pad	98	VA	99	VA
100	VA				

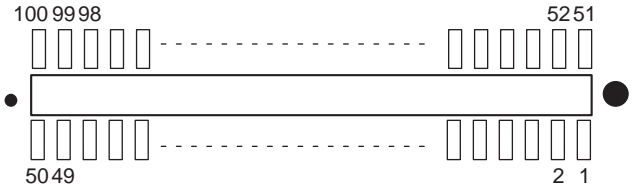

11. Inverter Connector

Pin	Description	Pin	Description	Pin	Description
1	VIN	2	BKLIN	3	VADJ
4	GND				

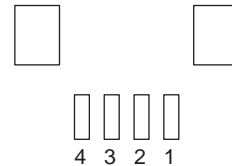

12. Switch Board Connector

Pin	Description	Pin	Description	Pin	Description
1	LID#	2	NBSWON#	3	GND

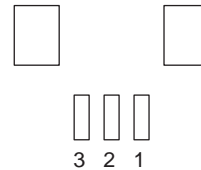

13. Fan Connector

Pin	Description	Pin	Description	Pin	Description
1	POWER	2	GND		

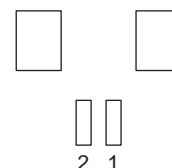

14. Battery Connector

Pin	Description	Pin	Description	Pin	Description
1	MBATV	2	KB_SMBCLK	3	VA
4	KB_SMBDATA	5	MID	6	Pull-Up
7	GND				



16. Glide Pad Connector

Pin	Description	Pin	Description	Pin	Description
6	TBCLK	5	TBDATA	4	N.C.
3	N.C.	2	GND	1	VCC

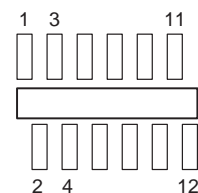

15. RTC Battery Connector

Pin	Description	Pin	Description	Pin	Description
1	VBAT1	2	GND		

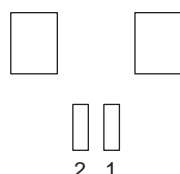

17. LCD Connector

Pin	Description	Pin	Description	Pin	Description
1	LCDVCC	2	LCDVCC	3	GND
4	GND	5	TX1OUT0-	6	TX1OUT0+
7	GND	8	TX1OUT1-	9	TX1OUT1+
10	GND	11	TX1OUT2-	12	TX1OUT2+
13	GND	14	TX1CLKOUT-	15	TX1CLKOUT+
16	GND	17	N.C.	18	N.C.
19	GND	20	GND		



18. Upper Board to Main Board Connector

Pin	Description	Pin	Description	Pin	Description
AA1	GND	AA2	AS1_A17_Y1	AA3	AS1_A8_Y2
AA4	AS1_A18_Y3	AA5	AS1_A9_Y0	AA6	GND
AA7	AS1_A13_Y4	AA8	AS1_A19_Y5	AA9	AS1_A14_Y6
AA10	AS1_A20_Y7	AA11	GND	AA12	AS1_B2/SPK_IDAT
AA13	AS1_INPK#_ILR	AA14	AS1_A7_ISCK	AA15	GND
AA16	IO_24M	AA17	GND	AA18	PCLK_PCIC
AA19	GND	AA20	PCLK_PPIX	AA21	GND
AA22	PCLK_MOD	AA23	GND	AA24	CON_14M
AA25	GND	AA26	FRAME#	AA27	IRDY#
AA28	TRDY#	AA29	DEVSEL#	AA30	PDAT_SMB_SDM
AA31	GND	AA32	CBE#1	AA33	CBE#2
AA34	CBE#3	AA35	CBE#0	AA36	PAR
AA37	STOP#	AA38	SERR#	AA39	PERR#
AA40	GND	AA41	CLKRUN#	AA42	PCIRST#
AA43	PHLD#	AA44	PHLDA#	AA45	GND
AA46	AD0	AA47	AD1	AA48	AD2
AA49	AD3	AA50	GND	AA51	AD4
AA52	AD5	AA53	AD6	AA54	AD7
AA55	GND	AA56	AD8	AA57	AD9
AA58	AD10	AA59	AD11	AA60	GND
AA61	AD12	AA62	AD13	AA63	AD14
AA64	AD15	AA65	GND	AA66	Test Pad
AA67	VIN	AA68	VIN	AA69	VIN
AA70	Test Pad				

Pin	Description	Pin	Description	Pin	Description
AB1	GND	AB2	AS1_A22_UV1	AB3	AS1_A16_UV2
AB4	AS1_A23_UV3	AB5	AS1_A21_UV0	AB6	AS1_A15_UV4
AB7	AS1_A24_UV5	AB8	AS1_A12_UV6	AB9	AS1_A25_UV7
AB10	AS1_A11-VS	AB11	GND	AB12	AS1_WP_PCLK
AB13	AS1_A10_HREF	AB14	GND	AB15	USB_48M
AB16	GND	AB17	Test Pad	AB18	Test pad
AB19	PIRQA#	AB20	PIRQB#	AB21	GND
AB22	REQA#	AB23	GNTA#	AB24	REQB#
AB25	GNTB#	AB26	REQ#0	AB27	GNT#0
AB28	REQ#1	AB29	GNT#1	AB30	REQ#2
AB31	GND	AB32	REQ#3	AB33	GNT#3
AB34	GNT#2	AB35	SERIRQ	AB36	PLOCK#
AB37	PCLK_SMB_SDM	AB38	GND	AB39	AD16
AB40	GND	AB41	AD17	AB42	AD18
AB43	AD19	AB44	GND	AB45	AD20
AB46	AD21	AB47	AD22	AB48	AD23
AB49	AD24	AB50	GND	AB51	AD25
AB52	AD26	AB53	AD27	AB54	GND
AB55	AD28	AB56	AD29	AB57	AD30
AB58	AD31	AB59	Test pad	AB60	GND
AB61	NMI	AB62	FERR#	AB63	INIT
AB64	IGNNE#	AB65	SMI#	AB66	INTR
AB67	A20M#	AB68	GND	AB69	GND
AB70	GND				

Pin	Description	Pin	Description	Pin	Description
BA1	GND	BA2	R	BA3	GND
BA4	G	BA5	GND	BA6	B
BA7	GND	BA8	DDC_CLK	BA9	DDC_DATA
BA10	VSYN	BA11	GND	BA12	HSYN
BA13	CRTSENSE	BA14	VGARST#	BA15	ENAVEE
BA16	GND	BA17	CON_32K	BA18	MCHG
BA19	MID	BA20	MBATV	BA21	GND
BA22	CPUON	BA23	KB_SMBCLK	BA24	KB_SMBDATA
BA25	HWPG	BA26	BL/C#	BA27	REFON
BA28	ACIN	BA29	REF5V	BA30	SUSON
BA31	GND	BA32	MAINON	BA33	HOST_STP#
BA34	PLL_STP#	BA35	STPCLK#	BA36	SUSTAT#1
BA37	SUSTAT#2	BA38	PCLK_SMB_GEN	BA39	PDATA_SMB_GEN
BA40	GND	BA41	PME#	BA42	GND
BA43	VGASUS	BA44	+3VSUS	BA45	+3VSUS
BA46	+3VSUS	BA47	+3VSUS	BA48	+3VSUS
BA49	Test pad	BA50	GND	BA51	GND
BA52	Test pad	BA53	+3VRUN	BA54	+3VRUN
BA55	+3VRUN	BA56	+3VRUN	BA57	+3VRUN
BA58	+3VRUN	BA59	Test pad	BA60	GND
BA61	GND	BA62	GND	BA63	Test pad
BA64	+5VSUS	BA65	+5VSUS	BA66	+5VSUS
BA67	+5VSUS	BA68	+5VSUS	BA69	GND
BA70	GND				

Pin	Description	Pin	Description	Pin	Description
BB1	GND	BB2	IAC_BITCLK	BB3	IAC_SYNC
BB4	IAC_SDATAI	BB5	IAC_SDATAO	BB6	IAC_REST#
BB7	DOC_RESET#	BB8	DOC_BIT	BB9	DOC_SYNC
BB10	DOC_SDATAI	BB11	GND	BB12	DOCSENSE#
BB13	DOC_SDATAO	BB14	LCDID0	BB15	LCDID1
BB16	LCDID2	BB16	LCDID3	BB18	Test pad
BB19	OVERHEAT#	BB20	SUSA#	BB21	GND
BB22	PWROK	BB23	TBCLK	BB24	TBDATA
BB25	GND	BB26	VOL_UP	BB27	VOL_DOWN
BB28	+12V	BB29	+12V	BB30	+12V
BB31	GND	BB32	VBAT1	BB33	VA
BB34	VA	BB35	VA	BB36	VA
BB37	VA	BB38	VA	BB39	Test pad
BB40	GND	BB41	GND	BB42	GND
BB43	Test pad	BB44	+5VRUN	BB45	+5VRUN
BB46	+5VRUN	BB47	+5VRUN	BB48	+5VRUN
BB49	Test pad	BB50	GND	BB51	Test pad
BB52	+5VRUN	BB53	+5VRUN	BB54	+5VRUN
BB55	+5VRUN	BB56	+5VRUN	BB57	+5VRUN
BB58	+5VRUN	BB59	Test pad	BB60	GND
BB61	GND	BB62	Test pad	BB63	Test pad
BB64	GND	BB65	GND	BB66	5VPCU
BB67	5VPCU	BB68	5VPCU	BB69	GND
BB70	GND				

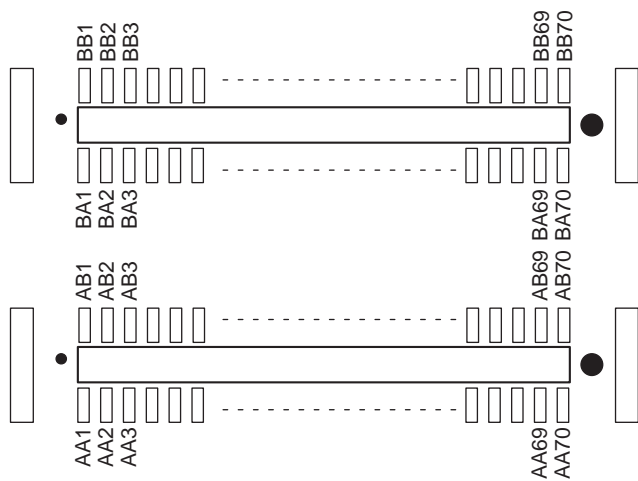

CHAPTER 7. TROUBLESHOOTING

This chapter analyzes system failures and describes the troubleshooting process.

POST Card

- A POST card is provided for troubleshooting. The POST card has eight LED indicators. These eight LEDs display POST codes. When the NOTEBOOK performs the POST, at the beginning of every test item of the POST, the BIOS will write a POST code to port address 378h. The POST card will show the POST codes on LED0 to LED7.
- The POST card has a 25-pin male D-SUB connector. Install the POST card by plugging the POST card to the system parallel port on the rear side of the NOTEBOOK. If the POST code isn't running and stops on a specific code that indicates a POST error, read the POST code to check which error occurred.
- Reading the POST card is easy. Appendix A has a summary of the POST codes written in hexadecimal. LED7 to LED 4 of the POST card are the most digits and LED3 to LED0 are the least digits. An LED on is '1' and off is '0' for example:

LED7	LED6	LED5	LED4	LED3	LED2	LED1	LED0	
OFF	OFF	ON	OFF	ON	OFF	OFF	OFF	
0	0	1	0	1	0	1	1	=2Bh

* If you refer to Appendix A, 2Bh means "screen memory test failure".

1. System Start Failure

When you turn on the power switch the NOTEBOOK will run the power-on-self-test (POST) before system boot-up. If the NOTEBOOK hangs up before boot-up this constitutes a system start failure.

System start failures include power supply failure, system reset failure, POST failure and boot-up failure.

1-1. Power Supply Failure

Turn on the power switch:

- The power of the NOTEBOOK is off.
- No screen display.
- No HDD motor spinning noise.

Priority Inspection

- If you are operating the NOTEBOOK using the battery:
 1. Perhaps the battery charge is exhausted. Replace the battery or plug in the AC adapter.
 2. Check if the battery contacts are secure or not.
- If you are operating it using the AC adapter:
 1. Check if the AC and DC power cords of the AC adapter is properly plugged in or not. If not, plug in the power cords. Then test it again.
 2. Check if the power LED on the AC adapter is on or not. If not, the AC adapter is damaged. Replace the AC adapter then test again.
 3. If everything checked is fine but the NOTEBOOK doesn't work this indicates that the power circuit of the NOTEBOOK isn't working properly. Check the power circuit of the NOTEBOOK.

1-2. System Reset Failure

Turn on the power switch:

- The power of the NOTEBOOK is on.
- No screen display.
- POST codes on the POST card are not running.

Priority Inspection

1. Check the system board power circuit.
2. Check CPU reset circuit.
3. Check the system board reset circuit.
4. Check the system clocking circuit.
5. Check to see if the BIOS has failed.
6. Check system board and upper board are fully connected.

1-3. POST Failure

- The NOTEBOOK power is on.
- No screen display.
- POST codes on the POST card are running and then stop at a specific code.

Priority Inspection

Read the error code and then compare it with Appendix A. Check the portion of the circuit or devices that the error code indicated.

1-4. POST or Boot-Up Failure

- POST codes on the POST card are running and then stop at a specific code.
- The screen displays a POST message when the POST is running and then stops on a specific condition or with an error message.

Priority Inspection

1. Read the error code and then compare it with Appendix A. Check the portion of the circuit or devices that the error code indicated.
2. Read the error message then compare it with Appendix A. Check the portion of the circuit or devices that the error message described.

2. Keyboard Failure

When pressing keys on the keyboard:

- Keyboard has no effect.
- Displays unexpected keys.
- Multiple keys display on one stroke.

Priority Inspection

1. Check if the keyboard cable is properly connected into the keyboard connector or not. If not, connect the keyboard cable properly.
2. If the keyboard still doesn't work, replace the keyboard then test again.
3. If the failure can't be clarified, check the keyboard relative circuit.

3. Video Failure

Video failures include LCD display failure and CRT display failure.

3-1. LCD Display Failure

LCD Failure:

- No display on the screen but the system still works.
- Regular vertical lines across the entire screen.
- Unexpected block shades on the screen.
- Unexpected vertical or horizontal lines on the screen.

Priority Inspection

1. Check if the LCD and inverter cables are properly connected or not. If not, connect the cables properly and test again.
2. Replace the LCD module then test again.
3. If LCD still doesn't display, check LCD control circuit.

3-2. CRT Display Failure

- No display on the screen but the system still works.
- Screen can't synchronize.
- Color of the screen is wrong.

Priority Inspection

1. Check if the monitor power is on or not. If not, turn on the monitor.
2. Check if the monitor cable is properly connected or not. If not, connect the monitor cable properly.
3. If the monitor still doesn't display an image, change to another monitor then test again.
4. If the monitor still doesn't display, check CRT relative circuit.

4. Disk Drive Failure

Disk drive failures include FDD, HDD and CD-ROM access failure.

4-1. FDD Failure

When you access the FDD:

- Can't read from a floppy disk.
- Can't write to a floppy disk.

Priority Inspection

1. Check if the connector to the FDD module is properly connected or not.
2. Disassembly the FDD module, check the FDD board and FPC.
3. If the FDD can't read or write switch to another diskette and try again.
4. Clean the read/write head of the FDD and try again.
5. If the FDD still doesn't work, change the FDD and try again.
6. If the FDD still doesn't work, check FDD relative circuit.

4-2. HDD Failure

When you access the HDD:

- Can't read from hard disk drive.
- Can't write to hard disk drive.
- Can't find operating system.

Priority Inspection

1. Check if the connector to the HDD is properly connected or not.
2. Install the HDD into another system unit and try again.
3. Reformat the HDD and try again.
4. If the HDD still doesn't work, change to another HDD and try again.
5. If the HDD still doesn't work, check HDD relative circuit.

4-3. CDROM Failure

When you access the HDD:

- Can't read from hard disk drive.
- Can't find operating system.

Priority Inspection

1. Check if the connector to the CDROM module is properly connected or not.
2. Disassembly the CDROM module, check the CDROM board.
3. If the CDROM still doesn't work, change the CDROM and try again.
4. If the CDROM still doesn't work, check FDD relative circuit.

5. Battery Failure

- Charge LED flashes when AC adapter connected.

Priority Inspection

1. Check if the battery contact springs are secure or not.
2. If the failure isn't resolved, change the battery and test again.

CHAPTER 8. DIAGNOSTICS

1. Items to be tested

The following items are tested.

- RTC
- HDD
- PARALLEL PORT
- VRAM
- MODEM
- FDD (720K)
- KEYBOARD
- LCD
- BMP DISPLAY
- PC CARD
- PS/2 MOUSE
- SHUT SWITCH
- IR
- BATTERY LIFE
- CPU CLOCK
- SERIAL PORT
- MEMORY
- VRAM SIZE
- FDD (1.44M)
- DATA CD
- LOCK KEY LED
- CRT OUTPUT
- SOUND
- GLIDE POINT
- USB
- FAN
- HDI

2. List of test tools

Testing process	Software	Optional device
Acceptance function test (1 and 2)	PC-A800 Diag install disk Diag data disk Infrared communication test receiver device software	Serial port loop-back connector
		Parallel port loop-back connector
		3.5-inch 1.44MB format R/W FD
		3.5-inch 1.25MB format R/W FD
		3.5-inch 720kB format R/W FD
		CRT monitor (possible to display in SVGA mode)
		CTAS USB host adapter
		PCMCIA SRAM card
		Music CD
		Testing CD Ver. 1.0
		IrDA testing receiver machine
		PS/2 mouse
		Expanded memory
System test		Music CD test CD Ver. 1.0
Aging test		3.5-inch 1.44MB format R/W FD test CD Ver. 1.0
Final function test		

3. Testing procedure

[Diag Install]

Item to be tested	Key operation	Indication	Judgement	Remarks
Preparation	Connect FD drive.			
	Set the Diag Install disk into FDD.			
	Connect AC adapter to the system unit.			
	Turn the power on.			
Set up BIOS	[F2]	Press <F2> to enter SETUP		
	[Esc]	Exit menu		
	[↓][↓][Enter][Enter]	Get Default Values		
	[→][→][→][→]	Boot menu		
	[↓][+]	Floppy Disk (Change to No.1)		
	[Esc]	Exit menu		
	[Enter][Enter]	Reboot		
Boot		Starting Windows 95c		
	[Enter]	Microsoft Windows 95 Startup Menu ----- 1. Diag Install 2. Diag Uninstall 3. Check HDI 4. Check Battery Cap. Enter a choice: 1		Select 1. Diag Install.
Install	[Y] or [N]	The hard disk image appears on screen.		
	(When [N] is selected) [Y] or [N]	- - - HDI Failed!!! - - - Continue Install? [Y] (Yes)/ [N] (No)		If [N] is selected, Diag is not installed. If [Y] is selected, the following continues.
	Remove the Diag Install disk from the FDD and Diag Data disk into FDD.	Please Change Startup FD to Data FD O.K.? [Yes]		
	[Y]			
		Install Finished!!!		
End	Turn the power off.			
	Remove the Diag Data disk from the FDD.			

[Troubleshooting]

Item to be tested	Key operation	Indication	Judgement	Remarks
Preparation	Connect the loop back connector to each port.			Connect the loop back connectors to both the serial port and the parallel port.
	Put the FD drive into the FD box.			
	Make the FD drive in outside connection			
	Turn the power on.			Use the battery pack for testing. (Use AC if the battery is low.)
Set up BIOS	[F2]	Press <F2> to enter SETUP		
	* [Esc]	Exit menu		The step marked * is not required if the procedure is continued from Diag Install
	* [↓][↓][Enter][Enter]	Get Default Values		
	* [→]	Main menu		
	(hour) [Enter]			
	(minute) [Enter]			
	[↓]			
	(month) [Enter]			
	(day) [Enter]			
	(year) [Enter]			
	[→][→][→]	Power menu		
	[Space]	PM Control: Disabled		

Item to be tested	Key operation	Indication	Judgement	Remarks
Set up BIOS	[→] [→]	Exit menu		
	[Enter] [Enter]	Reboot		
Reboot		Starting Windows xx...		Select 6. Trouble Shooting.
	[Enter]	Microsoft Windows xx Startup Menu ----- 1. Incoming Test 1 2. Incoming Test 2 3. System Test 4. Aging Test 5. Final Test 6. Trouble Shooting 7. Diag Uninstall Enter a choice: 1		

MENU screen

```

----- MENU -----
1. RTC                17. BMP DISPLAY
2. CPU CLOCK          18. MIC
3. HDD                19. SOUND WAVE
4. SERIAL PORT        20. PCMCIA
5. PRINTER PORT       21. GLIDE POINT
6. MEMORY              22. PS/2 MOUSE
7. VRAM                23. USB (1PORT)
8. VRAM SIZE           24. USB (2PORT)
9. MODEM               25. SHUT SWITCH
10. 1.44M FDD          26. FAN
11. 720K FDD           27. IR TEST (CLIENT)
12. MUSIC CD           28. HARD DISK IMAGE
13. DATA CD           29. BATTERY LIFE
14. KEY BOARD          30. BIOS VERSION
15. LOCK KEY LED       31. IR SERVER
16. LCD/CRT            32. ERROR LOG DISPLAY
ECHO IS OFF
No.=>_
    
```

Item to be tested	Key operation	Indication	Judgement	Remarks
Menu selection		<pre> --- MENU --- 1. RTC 17. BMP Display : 15. Rock Key LED 31. IR Server 16. LCD/CRT 32. Error Log No. => </pre>		
1. RTC	[1] [Enter] ----- [N] or [R]	(If the item fails the test) ----- [N] (NG)/ [R] (Retry) (If the item fails the test)	Automatic judgement	
2. CPU clock Cache Size	[2] [Enter] ----- [N] or [R]	(If the item fails the test) ----- [N] (NG)/ [R] (Retry) (If the item fails the test)	Automatic judgement	
3. HDD	[3] [Enter] ----- [N] or [R]	(If the item fails the test) ----- [N] (NG)/ [R] (Retry) (If the item fails the test)	Automatic judgement	
4. Serial port	[4] [Enter] ----- [N] or [R]	(If the item passes the test) ----- [N] (NG)/ [R] (Retry) (If the item fails the test)	Automatic judgement	* Only when the port replicator is connected
5. Parallel port	[5] [Enter] ----- [N] or [R]	(If the item fails the test) ----- [N] (NG)/ [R] (Retry) (If the item passes the test)	Automatic judgement	
6. Memory	[6] [Enter] ----- [N] or [R]	(If the item passes the test) ----- [N] (NG)/ [R] (Retry) (If the item fails the test)	Automatic judgement	
7. VRAM	[7] [Enter] ----- [N] or [R]	(If the item passes the test) ----- [N] (NG)/ [R] (Retry) (If the item fails the test)	Automatic judgement	

Item to be tested	Key operation	Indication	Judgement	Remarks
8. VRAM Size	[8] [Enter]	(If the item passes the test)	Automatic judgement	
	[N] or [R]	[N] (NG)/ [R] (Retry) (If the item fails the test)		
9. Modem	[9] [Enter]	(If the item passes the test)	Automatic judgement	
	[N] or [R]	[N] (NG)/ [R] (Retry) (If the item fails the test)		
10. FAD (1.44M)	[1] [0] [Enter] (Only when no medium is inserted.) Change to 1.44M R/W FD and press [Y].	Please Change System FD to 1.44 RW FD O.K.? [Yes]		* This message appears on screen if no medium is inserted into the FAD with FAD connected to an optional bay or the parallel port.
	No key operation required [N] or [R]	(If the item passes the test) [N] (NG)/ [R] (Retry) (If the item fails the test)	Automatic judgement	
11. FAD (720K)	[1] [1] [Enter] (Only when no medium is inserted) Change to 720K R/W FD and press [Y].	Please Change System FD to 720k RW FD O.K.? [Yes]		* This message appears on screen if no medium is inserted into the FAD with FAD connected to an optional bay or the parallel port.
	No key operation required [N] or [R]	(If the item passes the test) [N] (NG)/ [R] (Retry) (If the item fails the test)	Automatic judgement	
13. Data CD	[1] [3] [Enter]			
	The CD tray automatically opens. Remove music CD and set test CD and press [Y].	Please Change Music CD to Data CD O.K.? [Yes]		
	No key operation required. [N] or [R]	(If the item passes the test) [N] (NG)/ [R] (Retry) (If the item fails the test)	Automatic judgement	
	[1] [4] [Enter]			
14. Keyboard	Press all keys.	The keyboard layout appears on screen.	After all keys are pressed successfully, a judgment of "Pass" is made. If any key is defective, end the operation by pressing the [Esc] key twice. (An error judgment is made.)	
15. Lock key LED	[1] [5] [Enter]			
	[Y] or [N]	Caps Lock Num Lock Scroll Lock The three LEDs continue blinking	This item passes the test if the three LEDs blink.	
16. LCD/CRT	[1] [6] [Enter]			
	Connect the CRT monitor to the system unit.		The gradation should be normal.	Press [Fn] + [F5] to change over to the simultaneous mode.
	[Space]...	The gradation in red, green blue and white appears on screen.		
	[Space]...	2 horizontal lines and 2 vertical lines		
	[Space]...	Black and white		
	[Space]	RGB mesh		
	[Y], [N] or [R]	O.K.? : [Y] (Yes)/ [N] (No)/ [R] (Retry)		
Disconnect the CRT monitor.				
17. BMP Display	[1] [7] [Enter]			
	Connect the CRT monitor to the system unit.			
	[Space]	Mebius wall paper 1		
	[Space]	Mebius wall paper 2		
	[Y], [N] or [R]	O.K.? : [Y] (Yes)/ [N] (No)/ [R] (Retry)		
	Disconnect the CRT monitor.			

Item to be tested	Key operation	Indication	Judgement	Remarks
18. Mic Test	[1] [8] [Enter]	--- Starting Mic Test ---		
		--- -Press any key to start recording...- ---		
	Press any key.	--- And press any key to interrupt recording & start playing ---		
	Press any key.	Recording from internal AC97 link Kbytes Recorded=xxx		Tap the microphone a few times and press any key.
	[Y], [N] or [R]	Playing to internal AC97 link O.K.? : [Y] (Yes)/ [N] (No)/ [R] (Retry)	The item passes the test if tapping sound is heard from the speaker.	
19. Sound Wave	[1] [9] [Enter]	--- Starting Sound Test ---		
	[Y], [N] or [R]	Playing to internal AC97 link O.K.? : [Y] (Yes)/ [N] (No)/ [R] (Retry)	The item passes the test if any sound is heard from the speaker.	
20. PCMCIA	[2] [0] [Enter]		Automatic judgement	Insert 2 SRAM cards into the PCMCIA slots.
	Insert two PC cards into the PC-card slots and press [Y].	Insert 2 SRAM Card to every PCMCIA slot		
	No key operation required (when the item passes the test)	O.K.? [Yes]		
	[N] or [R] (when the item fails the test)	*** FILE OPEN (WRITE) ERROR *** [N] (NG)/ [R] (Retry)		
21. Glide Point	[2] [1] [Enter]	The glide point icon appears on screen.	If all actions are successfully observed, the item passes the test.	The cursor first appears at the middle of the screen. Move the cursor to the top of the screen and then move it down to the bottom of the screen.
	Click the left button.	The left button of the glide point blinks.		
	Click the right button.	The right button of the glide point blinks		
	Tap	The left button of the glide point blinks.		
	Move the cursor.	The cursor moves.		
	[Y] or [N]			
22. PS/2 Mouse	[2] [2] [Enter]		Automatic judgement	If you cannot exit the program by pressing the right button of the mouse, press the [N] key to exit the program (error judgement)
	Press the right button of the mouse.	PS/2 Mouse Test Click the Right Button of the Mouse If the Mouse is N.G., press N-key to Exit		
23. USB (1 port)	[2] [3] [Enter]		Automatic judgement	When a single USB port is equipped on the system unit.
	Connect the USB checker cable to the USB port 1 and press [Y].	Please Connect USB Cable to USB Port O.K.? [Yes]		
		The USB Port Test program screen appears.		
	[Any key]	(When the item passes the test)		
	[N] or [R]	[N] (NG)/ [R] (Retry) (When the item fails the test)		
24. USB (2 ports)	[2] [4] [Enter]		Automatic judgement	When there are two USB ports (when a port replicator is connected).
	Connect USB checker cables to the USB ports 1 and 2 and press [Y].	Please Connect USB Cable to USB Port O.K.? [Yes]		
	[Any key]	(When the item passes the test)		
	[N] or [R]	[N] (NG)/ [R] (Retry) (When the item fails the test.)		
25. Shut Switch	[2] [5] [Enter]		Automatic judgement	
	Close the cover.	--- Suspend Test --- O.K.? [Y] (Yes)/ [N] (No)		
	Open the cover			
	[Any key]			
	After making sure the system has been returned to normal mode, press [Y].		Make sure the system resumes from the Suspend mode.	
26. Fan	[2] [6] [Enter]	The PC-A800 Fan Test screen appears (ON)	Make sure the fan is rotating.	
	[→]	(OFF)	Make sure the fan is at rest.	
	[Y] or [N]		The item passes the test if the fan rotates and stops normally.	

Item to be tested	Key operation	Indication	Judgement	Remarks
27. IR	[2] [7] [Enter]			Set up an IR client PC in advance.
	[Any key]	--- IR Communication Test ---		
	No key operation required. [N] or [R]	(When the item passes the test) [N] (NG)/ [R] (Retry) (When the item fails the test)	Automatic judgement	
29. Battery Life	[2] [8] [Enter]	relative state of charge: xx %		Record the residual battery voltage.
	[Any key]	Press any key to continue...		
	[Y] or [N]	O.K.? : [Y] (Yes)/ [N] (No)		
30. BIOS version	[3] [0] [Enter]			Check against the check list published by the 2nd Technical Div. of Personal Computer Dept.
	[Y] or [N]	***** BIOS Version ***** Version=x.xx O.K.? : [Y] (Yes)/ [N] (No)		
End	Open the CD-ROM drive tray and remove the Data CD.			
	Turn the power off			
	Remove the loop back connectors.			
	Remove the USB cables from the USB ports			
	Remove the two SRAM cards.			
	Remove the FD.			

[Setting up an IR client PC for testing IrDA communication port]

Item to be tested	Key operation	Indication	Judgement	Remarks
Preparation	Turn the power ON.			As a client PC, use the PC-BJ100M (Diag. program installed).
Set up BIOS	[F2]	Press <F2> to enter SETUP		
	[Esc]	Exit menu		
	[↓][↓][Enter][Enter]	Get Default Values		
	[→][→][→]	Power menu		
	[Space]	Power Management: Disabled		
	[→][→]	Exit menu		
	[Enter][Enter]	Reboot		
Boot		Starting Windows xx...		Select 6. Trouble Shooting
	[↓][↓][↓][↓][↓][↓][Enter]	Microsoft Windows xx Startup Menu ----- 1. Incoming Test 1 2. Incoming Test 2 3. System Test 4. Aging Test 5. Final Test 6. Trouble Shooting 7. Diag Uninstall Enter a choice:		
Menu selection	[3] [1] [Enter]	----- MENU ----- 1. RTC 17. BMP Display : 15. Rock Key LED 31. IR Server 16. LCD/CRT 32. Error Log No. =>		Select 31. IR Server.
IR (Client PC)	[Y]	Please setup the IR client PC O.K.? [Yes]		Put a client PC faced to the set you want to test with its IR port at an angle of 0##### at a distance of 30 to 40 cm between them.
End	[ESC]	Press any key to continue...		
	[Enter]	----- MENU -----		
	Turn the power OFF.			

[Checking Hard Disk Image]

Item to be tested	Key operation	Indication	Judgement	Remarks
Preparation	Remove the CD-ROM drive and mount the FD drive.			
	Set the Diag. Install disk into the FD drive.			
	Connect the adapter.			
	Turn the power ON.			
Set up BIOS	[F2]	Press <F2> to enter SETUP		
	[↓][↓][↓][↓][Enter]	Boot Device Priority menu		
	[↓][Space]	Diskette Drive (Change to 1.)		
	[Esc]	Main menu		
	[Esc]	Exit menu		
	[Enter][Enter]	Reboot		
Boot		Starting Windows 95...		
	[↓][↓][Enter]	Microsoft Windows 95 Startup Menu ----- 1. Diag Install 2. Diag Uninstall 3. Check HDI 4. Check Battery Cap. Enter a choice: 1		Select 3. Check HDI.
Hard Disk Image		The HDD image appears on screen.		Check against the check list published by the 2nd Technical Div. of the Personal Computer Dept.
Default setting	[Ctrl] + [Alt] + [Del]	Reboot the system.		
	[F2]	Press <F2> to enter SETUP		
	[Esc]	Exit menu		
	[↓][↓][Enter][Enter]	Get Default Values		
	[↓][↓][↓][↓][Enter][Enter]	Save Changes		
End	Turn the power OFF.			
	Remove the Diag. Install disk from the FD drive.			
	Remove the FD drive and mount the CD-ROM drive.			

[Uninstalling the Diag. program]

The following procedure is usually not required because the Diag. program is deleted after the final test is finished.

If uninstallation of the Diag. program is required for any reason,, follow the procedure given below.

Item to be tested	Key operation	Indication	Judgement	Remarks
Preparation				
	Connect the adapter to the system unit.			
	Turn the power ON.			
Boot		Starting Windows xx...		
	[↓][↓][↓][↓][↓][↓][↓][Enter]	Microsoft Windows xx Startup Menu ----- 1. Incoming Test 1 2. Incoming Test 2 3. System Test 4. Aging Test 5. Final Test 6. Trouble Shooting 7. Diag Uninstall Enter a choice: 1		Select 7. Diag. Uninstall.
Uninstalling Diag. program	No key operation is required.	Reading dir(s)... xx File(s) deleted D:\>		
Default setting	[Ctrl] + [Alt] + [Del]	Reboot the system.		
	[F2]	Press <F2> to enter SETUP		
	[Esc]	Exit menu		
	[↓][↓][Enter][Enter]	Get Default Values		
	[↓][↓][↓][↓][Enter][Enter]	Save Changes		
End	Turn the power OFF.			

CHAPTER 9. BLOCK DIAGRAR SYSTEM BLOCK DIAGRAR

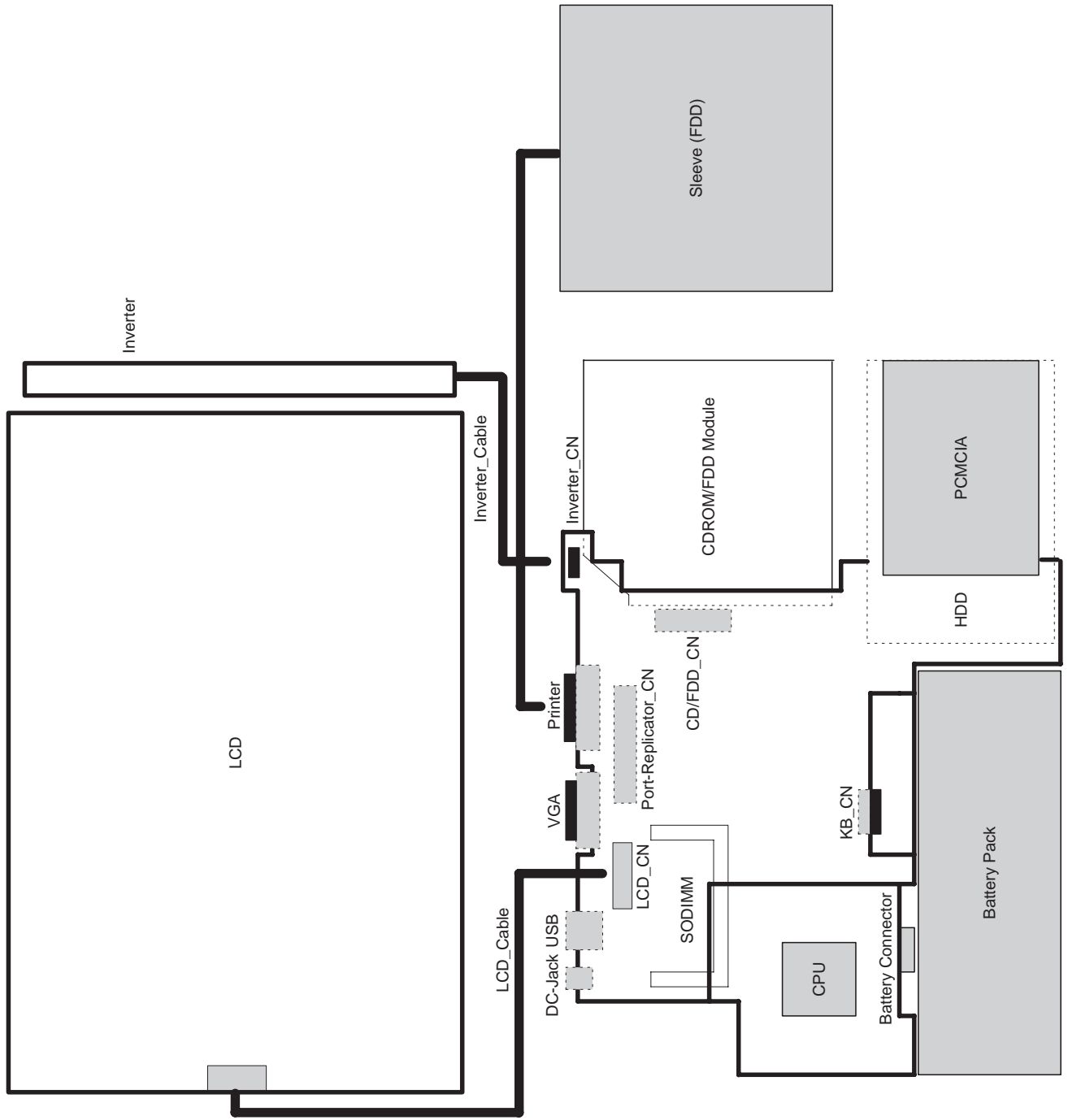

BLOCK DIAGRAM (BOARD)

