

# SHARP SERVICE MANUAL

CODE: 00ZPCA100SM-E



## PERSONAL COMPUTER

### MODEL PC-A100

#### CONTENTS

CHAPTER 1. OUTLINE .....	1-1
CHAPTER 2. SPECIFICATIONS .....	2-1
CHAPTER 3. DISASSEMBLY AND REASSEMBLY .....	3-1
CHAPTER 4. PRECAUTIONS .....	4-1
CHAPTER 5. RE-INSTALLATION .....	5-1
CHAPTER 6. BLOCK DIAGRAM .....	6-1
CHAPTER 7. CIRCUIT DIAGRAM AND PARTS LAYOUT .....	7-1

Parts marked with "⚠" is important for maintaining the safety of the set. Be sure to replace these parts with specified ones for maintaining the safety and performance of the set.

### **Caution about Battery**

**Caution:** Danger of explosion if battery is incorrectly replaced. Replace only with the same or equivalent type recommended by the manufacturer. Discard used batteries according to the manufacturer's instructions.

**Attention:** Il y a danger d'explosion s'il y a remplacement incorrect de la batterie. Remplacer uniquement avec une batterie du même type ou d'un type recommandé par le constructeur. Mettre au rebut les batteries usagées conformément aux instructions du fabricant.

# CHAPTER 1. OUTLINE

## 1. System Overview

The PC-A100 is a B/5-size subnotebook computer with a Tillamook 233-MHz MMX Pentium processor, 64 MB of memory as standard equipment. Compact in size, yet it has a wide viewable area by using a 11.3-inch SVGA (800 × 600) active-matrix display. Its 17-mm pitch, 2.5-mm stroke keyboard allows easy key operations. With an expansion battery pack installed, the machine operates for up to 8.5 hours continuously.

## 2. Overview of Computer

### Front

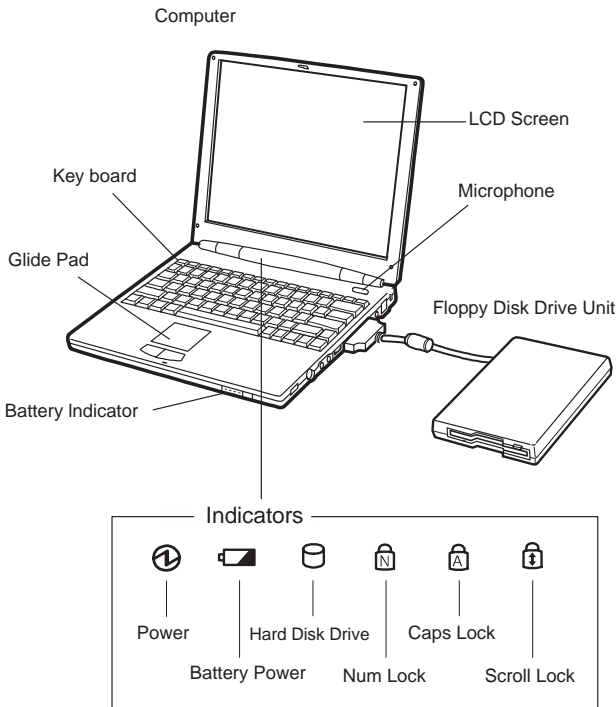

### Right

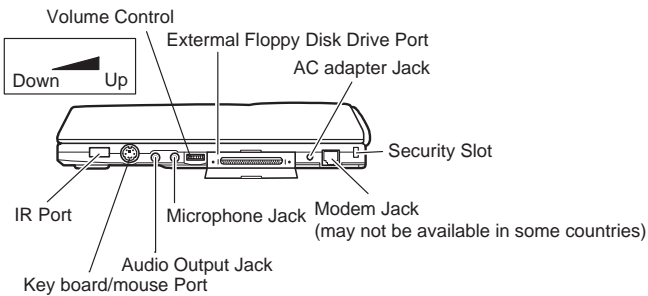

### Left

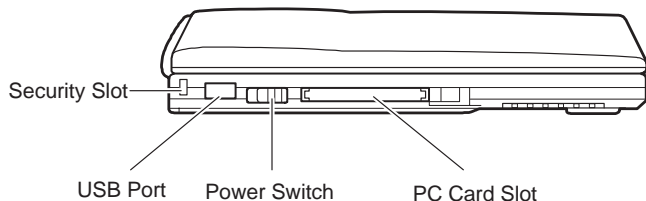

### Rear

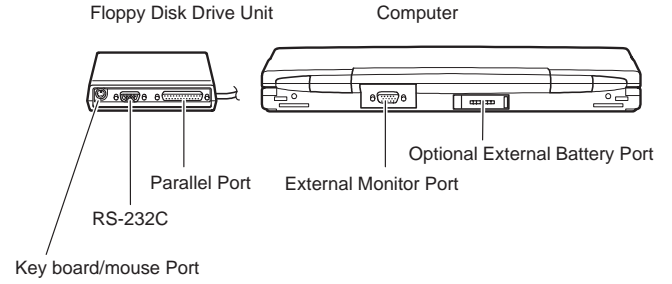

### Bottom

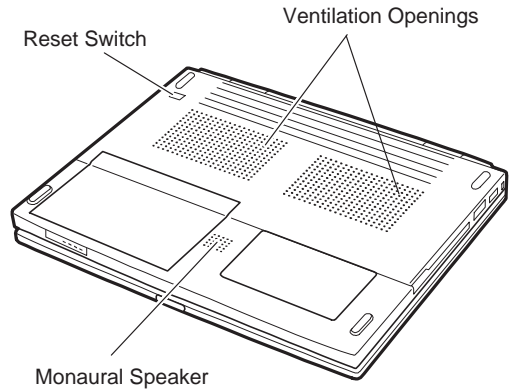

## 3. Basic Operations

This chapter describes the basic operations of your computer.



### Choosing Power Source

You can use the computer with one of the following power sources:

- AC power from a wall outlet  
Use AC power whenever possible; rely on the battery only when AC power is not available.
- Rechargeable battery  
There is an internal standard battery in the computer. You can use an optional external battery pack adding to the standard battery.

### About the Power Indicators

The following indicators show the power status of your computer.

Indicator	Light	Meaning
	On (green)	Fully charged
	On (orange)	Being charged
	Blinking (orange)	In abnormal state
	On and blinking (red)	Almost completely discharged. The warning beep sounds.
	On (green)	Operating
	Blinking (green)	Suspended to RAM
	Off	Suspended to Disk or powered off

## Using the AC Adapter

When connected to a wall outlet, the AC adapter provides power for operation and charges the battery. The AC input voltage can range from 100 to 240 volts so that you can use the computer with the appropriate plug adapter.



The AC power cord included with the computer is appropriate for the voltage used in the area in which you purchased your computer. If you attempt to connect the computer to a wall outlet other than in this area, check the voltage of the outlet and use an AC power cord appropriate for the outlet. Consult local service staff if you are unsure.

## Resetting the System

You may need to reset the system after adding hardware or software so that your computer will recognize the newly installed devices or software. When the message appears after the installation, click OK, Yes, etc. to restart Windows 98.

You can also restart Windows 98 from the Start menu. Select Shut down; then, Restart.

### Warm Boot

If the system is locked up because of a software problem, you can reset or reboot the system by pressing the Ctrl+Alt+Del keys simultaneously. Press the Ctrl+Alt+Del keys again to restart the computer.



Resetting may cause data loss. Use the software reset only if the normal Windows 98 Shut Down does not work because of software malfunction.

Although resetting will not damage the system, you may lose the data you are processing.

### Power Switch

You can turn off the computer with the power switch if you encounter hardware or software problems which lock up the system. In this case, slide and hold the switch for more than five seconds.

### Reset Switch

If you cannot turn off the computer by sliding the power switch, you can use the reset switch on the bottom of your computer. To reset the system, insert a narrow object into the small hole to slide the switch as shown.

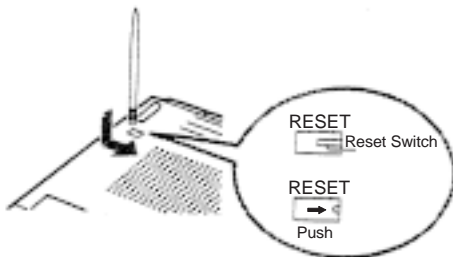

Do not use metallic materials to slide the reset switch. It may cause malfunction.

## Using The Glide Pad

Your computer is equipped with an integrated pointing device called a glide pad. Using the glide pad, you can move the pointer, select an item from a menu, and perform other tasks in the same way you would with a mouse.



- Do not hit or scratch the surface of the glide pad with pointed objects (such as a ballpoint pen).
- Do not operate the glide pad with a moist finger. This may cause the glide pad to operate incorrectly.
- You cannot use the glide pad when a mouse is connected.

## Using the Glide Pad

Take a moment to become familiar with how the glide pad works.



### Place Your Fingertip

Place your left or right hand next to the glide pad, resting your wrist naturally in a relaxed manner. Place your thumb or finger on the glide pad.

### Move Your Fingertip

The rectangular pad of the glide pad acts like a miniature duplicate of the display. As you slide your fingertip across the pad, the pointer on the screen moves in the same direction across the screen. The glide pad is very sensitive, so you do not have to exert a lot of pressure on the pad. The glide pad will respond to a light touch from your fingertip.

### Click, Double-click, and Right-click

To click or double-click, you can use the left button just like that of a mouse. Instead of clicking by pressing the left button, you can just tap gently anywhere on the rectangular pad. For right-clicking, you can use the right button.

### Drag and Drop

You can move icons or windows by using "drag and drop" below:

1. Position the pointer over the object.
2. Press the left button; do not release it.
3. Holding down the button, move the pointer. The object moves together with the pointer.
4. Release the button when the object reaches its destination.

### Changing the Configuration

In the Mouse Properties dialog box, you can change the configuration of the glide pad, such as swapping left and right buttons, changing the pointer size, etc.



- If you swap the left and right buttons, "tapping" on the glide pad as an alternative method of pressing the left button will no longer function.
- If you prefer to use a mouse and turn off the glide pad, you can disable the glide pad in the Setup Utility.

## Using The Keyboard

Your computer, equipped with the Windows Enhanced Keyboard, provides all the functionality of a full-sized desktop keyboard.

### Windows Logo Keys



Opens the Windows Start menu.



Opens an application-specific short-cut menu equivalent to right-clicking.

## System Function Keys

When pressed together with the Fn key, function keys set specific system parameters. This combination is sometimes referred to as "hot keys".



Switches the display output between the LCD screen and external monitor (if connected). See the Display section in Chapter 4 for details.



Decreases the LCD screen brightness.



Increases the LCD screen brightness.



Turns the screen backlight on and off.



Puts the computer in suspend mode (to RAM or to Disk, according to the setup selection).

## Using External Floppy Disk Drive Unit

You can use double-density (2DD) 720KB or high-density (2HD) 1.44MB floppy disks with the external floppy disk drive unit.

The keyboard/mouse port, RS-232C serial port and parallel port are available on the rear side of the floppy disk drive unit. You can connect peripherals to the floppy disk drive unit.

### Connecting External Floppy Disk Drive Unit



Turn off the computer before connecting the external floppy disk drive unit; otherwise the floppy disk drive unit may not be recognized.



- Do not place the floppy disk drive unit on its side or upside down.
- Do not press on the floppy disk drive unit. It may damage the drive or cause malfunction.
- Do not place the AC adapter on the floppy disk drive. It may cause the drive to malfunction.

1. Turn off the computer.
2. Open the cover of the external floppy disk drive port on the right side of the computer.
3. Connect the connector of the floppy disk drive unit to the floppy disk drive port.



## Removing External Floppy Disk Drive Unit

1. Remove the floppy disk from the floppy disk drive.
2. Turn off the computer.
3. Disconnect the floppy disk drive unit by simultaneously pressing the buttons on each side of the connector and pulling it out.
4. Close the cover of the floppy disk drive port.

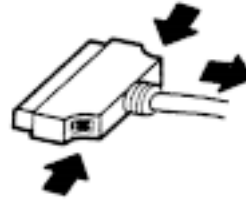

## Handling Floppy Disks

- Do not open the shutter and touch the disk inside; otherwise, you will not be able to read or write data to the disk.
- Do not place floppy disks near magnets or heat source, in direct sunlight or in a dusty place, etc.
- Never subject a disk to sudden shocks or extreme vibration. Do not drop, bend, or place heavy objects on a disk.
- Do not spill liquid onto a disk.

## Inserting and Removing a Floppy Disk

### Inserting

Hold the floppy disk with the arrow facing up and towards the drive. Slide the disk into the drive until it locks into place.

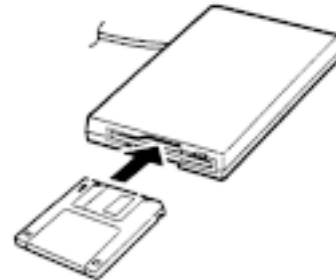

- Always insert a floppy disk straight into the computer.
- When inserting the disk, make sure it is not upside down.
- Do not use excessive force when inserting the floppy disk. If you have difficulty inserting or removing disks, seek the assistance of an authorized service technician.

### Removing



Before removing the floppy disk, make sure the indicator of the floppy disk drive unit is not lit.

Press the eject button firmly. The disk will pop out slightly. Remove it and store it properly.

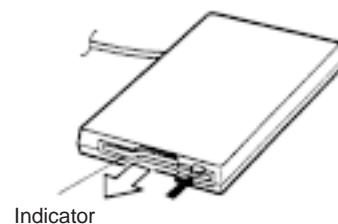

## Formatting a Floppy Disk

1. Make sure the floppy disk is not write-protected, and insert it into the floppy disk drive.
2. Double-click My Computer on the desktop.
3. Click 3 1/2 Floppy [A:]. From the File menu, select Format.
4. From the capacity drop-down list, select 1.44MB or 720KB.
5. Click Start to start formatting.



When you format a floppy disk, all data previously stored on the disk is lost.

## Backing Up Data

We recommend that you regularly backup the data on your hard disk drive. Windows 98 has a backup function you can use to back up your data. See Windows 98 Help for details.

## 4. Battery and Power Management

This chapter explains how to manage the computer's power effectively and use the standard battery or an optional battery pack.

### Standard Battery Pack

When not connected to an external power source, your computer operates with the rechargeable internal standard battery pack. The duration of the battery life may be longer if the computer's Power Management is active. See the next section for power management.

To keep the battery life long:

- Initialize the battery pack if the actual remaining power in your battery is less than what the battery indicator lights suggest.
- Turn off your computer when you are not using it.
- The duration a battery charge will last will depend on the computer usage. Applications which heavily use the peripherals, like the external floppy disk drive unit or the optional external CD-ROM drive, will experience shorter power duration.
- When the battery is not charged, your computer may not operate properly. Connect the AC power to charge the battery.
- If you see an error message during booting, press F2 to open the Setup Utility. Adjust the Setup Utility and restart the system.
- When using the computer for several hours with battery packs, enable power management and set the suspend-to-disk mode.



### Checking the Battery Level

You can check the battery level in the Power Management properties dialog box in the Control Panel or double-clicking the battery or AC plug icon on the taskbar.

You can also check with the battery indicator on the front side of the computer.

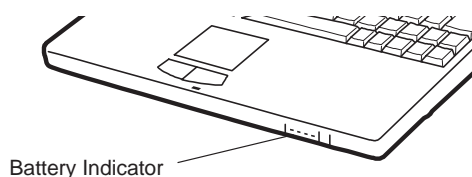

Press the button on the right of the battery indicator to show the battery power remaining. Refer to the table below.

Battery Indicator Status	Capacity Remaining
(All on)	76%-100%
(Three on)	51%-75%
(Two on)	26%-50%
(One on)	1%-25%
(All off)	0%(Empty)

This battery indicator turns on automatically while the battery is being charged (when connected to AC power). When the battery is fully charged, the battery indicator turns off.



The battery power remaining is an approximate figure. The remaining operating time expected may be different from the actual remaining time, depending on the use of the computer. If the actual remaining power in your battery is less than what the battery indicator lights suggest, you should initialize the battery pack.

### Low Battery Indication

When the battery power becomes significantly low, the battery power indicator ( ) turns red and the warning beep sounds. Save your data and turn off the computer, or connect the computer to a wall outlet immediately. If you set Critical Battery Suspend to Enabled in the Power menu of the Setup Utility, the computer will be suspended to disk in case of significantly low battery power. When your computer suspends, do not turn on the computer before connecting to a wall outlet or connecting a fully charged optional external battery pack.

In Windows 98, you can set the alarm to inform you of the remaining battery level. In Power Management properties dialog box, select Alarms tab and set Low battery alarm and Critical battery alarm.

The remaining operating time depends on the power you are consuming. If you are using the audio system, PC card slot, hard disk drive or external floppy disk drive unit, your computer may consume more battery life.



See also the section on power management in this chapter.

### Charging the Battery Pack

1. Connect the AC adapter to the computer. While the battery is being charged, the battery power indicator is orange and the battery indicator turns on.
2. When the battery is fully charged, the battery power indicator turns green and the battery indicator turns off. Charging time may vary according to the status of the computer.



When the battery is hot (for example, after long use), it may take longer to fully charge the battery.

## Initializing the Battery Pack

You need to initialize the battery pack when the actual remaining power in your battery is less than what the battery indicator lights suggest.

1. Connect the computer to AC power and wait until the battery is fully charged. The battery power indicator turns green and the battery indicator turns off. It will take about 2 hours and 30 minutes if the battery is completely discharged.
2. Turn on the computer.
3. When the message Press <F2> to enter Setup Utility appears, press F2 to open the Setup Utility.
4. Disable the power management and set Critical Battery Suspend to Disabled in the Power menu of the Setup Utility. See Disabling Power Management in this chapter and Power menu.
5. Press Esc; then Enter twice. The system restarts.
6. When the message Press <F2> to enter Setup Utility appears, press F2 to open the Setup Utility. Leave the computer in the Setup Utility.
7. Disconnect the AC adapter, and leave the computer until the battery is completely discharged and the system shuts down automatically. It will take about 3 hours.
8. Connect the computer to the AC adapter and let the battery fully charge.



- Do not connect the computer to wall outlet while discharging the battery. The initialization will be cancelled.
- You can initialize the standard battery alone only if the optional external battery pack is disconnected. When the external battery pack is connected, both the standard and the external battery will be initialized together.

## Changing the Battery Pack

The capacity of a battery pack gradually decreases when used repeatedly (the deterioration rate depends on the operating temperature and environment). If the battery life becomes extremely short even after the initialization, you should change the standard battery pack.

## Optional External Battery Pack

You can use an optional external battery pack to power your computer for longer periods of time.



- Use only the appropriate optional external battery pack (CE-BL03), and attach it correctly.

## Connecting External Battery Pack

1. Slide the cover of the external battery port to locate the port.

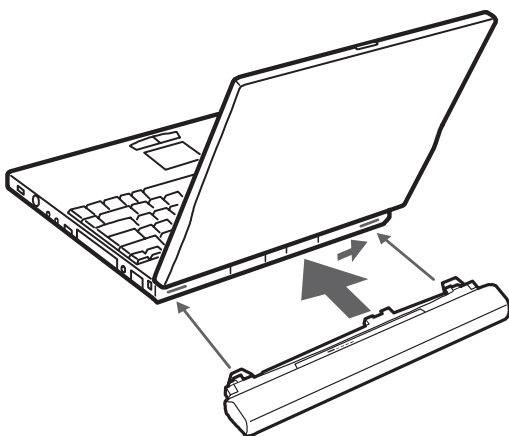

2. Connect the optional battery by matching the projections on either of the battery side to the notched parts of the computer. Make sure that the battery connector lines up with the external battery port of the computer. If you hear the clicking sound, the external battery pack is correctly connected.



- While the external battery pack is connected, do not carry the computer by holding the computer only. Firmly hold both the computer and the external battery pack.
- You cannot connect an external monitor when the external battery pack is connected.

## Removing External Battery Pack



Before removing the external battery pack, turn off the computer or confirm that the standard battery pack has power remaining. If the standard battery pack has no power remaining, connect the computer to AC power; otherwise the computer will be shut down and data may be lost.

Remove the optional battery by pressing the buttons on each end of the battery and sliding the battery off the computer.

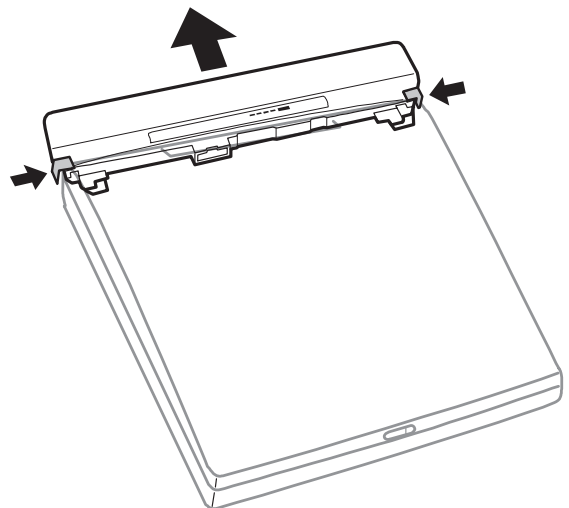

- Close the cover of the external battery port after the external battery pack is removed.

## Checking the Battery Level

You can check the battery level of the external battery pack (in the same way as the standard battery pack) with the battery indicator. Press the button on the right of the indicator. The status of the indicator is the same as that of the standard battery.

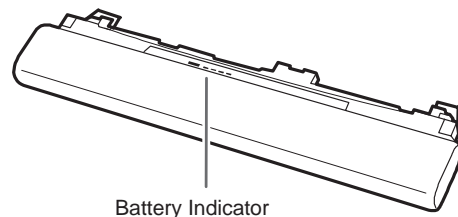

## Charging External Battery Pack

You can charge the external battery pack by connecting AC power to the computer with the external battery connected.

To charge most effectively, the standard and external battery pack will be charged as follows:

1. Charge standard battery pack to 80%.
2. Charge external battery pack to 80%.
3. Charge standard battery pack remaining 20%.
4. Charge external battery pack remaining 20%.

When the computer is turned off or in the suspend-to-disk mode, it will take about 5 hours and 30 minutes to charge both the standard and external battery packs from empty to full. When the computer is turned on, it will take about 7 hours and 30 minutes. (The charging time depends on the power you are consuming.)

## Initializing External Battery Pack

The procedure for initializing an external battery pack is the same as that of the standard battery. But, you cannot initialize the external battery pack only. If you begin the initializing process, both standard and external battery packs will be initialized.

## Power Management

Power management saves electricity and extends battery life by controlling power supply to built-in devices. You can set the power management properties in the Setup Utility or in Windows 98. Your computer is controlled by the power management settings in which the time set is shorter.



Note that the power management may not seem to function in the following conditions:

- When you are using an application program that accesses the hard disk periodically
- When the IR monitor is available
- When Windows CD Auto Play is functioning

## Stopping Power Supply to the Hard Disk

### Setting in Windows 98

1. In the Power Management Properties dialog box, select Power Schemes tab.
2. Set Turn off hard disks to an appropriate value, and click OK.

### Setting in the Setup Utility

In the Power menu, set Power Management Function to Enabled and set Hard Disk Power Down after to an appropriate value.

## Stopping Power Supply to the Display



This procedure is also effective for an attached external monitor complying with power management.

### Setting in Windows 98

1. In the Power Management Properties dialog box, select Power Schemes tab.
2. Set Turn off monitor to an appropriate value, and click OK.

### Setting in the Setup Utility

In the Power menu, set Power Management Function to Enabled and set Video Power Down after to an appropriate value.

## Suspend Modes

The power management contains two types of suspend modes: suspend-to-RAM mode and suspend-to-disk mode. In the Setup Utility, you can define which suspend mode the system enters in what conditions.

- Suspend-to-RAM mode stores the current condition of the computer in RAM and stops power supply to all but a few essential components. Your system enters and resumes from the suspend-to-RAM mode per the conditions mentioned below. In the suspend-to-RAM mode, the Power indicator blinks green.
- Suspend-to-disk mode saves the current condition of the computer in an area of the hard disk, which is called "suspend-to-disk partition," and turns off the computer. Your system enters and resumes from the suspend-to-disk mode per the conditions mentioned below. In the suspend-to-disk mode, the Power indicator turns off.

### Before suspending the system

Finish communications, printing, and playing music or video.

### Entering the Suspend modes

Your computer enters a suspend mode in each of the following cases. You can select the suspend mode that the system will enter in Suspend Mode in the Power menu of the Setup Utility.

- You slide the power switch when the item Power Switch Function is set to Suspend/Resume in the Setup Utility.
- You press Fn+F12.
- The specified time in System Standby of Power Management Properties dialog box has passed without any operation.
- You select Standby in the Shut Down Windows dialog box.

You can select the suspend mode that the system will enter in Cover Close in the Power menu of the Setup Utility.

- The screen cover is closed.

The following case functions if Critical Battery Suspend is set to Enabled in the Power menu of the Setup Utility.

- The battery level is low (always suspended to disk).

### Resuming from Suspend-to-RAM mode

Your computer resumes from the suspend-to-RAM mode in each of the following cases:

- You press any key.
- The screen cover is opened.
- The built-in modem receives a call if Resume On Modem Ring in the Power menu of the Setup Utility is set to Enabled (the built-in modem may not be available in some countries).
- You slide the power switch when the item Power Switch Function is set as Suspend/Resume in the Setup Utility.

### Resuming from Suspend-to-Disk mode

Your computer resumes from the suspend-to-disk mode by sliding the power switch. The system restores the exact state as it was when entering the suspend mode. If the computer enters the suspend mode due to low battery power, however, you have to connect the computer to AC power first. Suspend to Disk is useful when you want to turn off the computer and reopen the same windows after turning it on.



- If your battery becomes completely discharged during Suspend to RAM, you will lose unsaved data and will need to reboot your computer. Therefore, if you are planning to leave your computer suspended for long periods of time, we recommend Suspend to Disk.
- When the system enters or resumes from the suspend-to-disk mode, you can see some flicker on the display. This is not a malfunction.
- If sufficient battery power does not remain, your computer will not resume from the suspend-to-disk mode. To resume it from the suspend- to-disk mode, connect the computer to AC power.
- If a PC card does not work properly after your computer resumes from the Suspend to Disk, restart the computer.



When entering or resuming from a suspend mode, be sure to observe the following precautions. Otherwise, the computer may not operate correctly after it has resumed from the suspend mode.

- Do not turn off the computer when the system is suspended to RAM. The RAM contents will be lost.
- Do not operate the keyboard, glide pad or mouse while the system is entering or resuming from a suspend mode.

## Disabling Power Management

### In Windows 98

1. In the Power Management Properties dialog box, select Power Schemes tab.
2. Set System Standby, Turn off monitor and Turn off haddisks to Never, and click OK.

### In the Setup Utility

1. In the Power menu, set Power Management Function to Enabled.
2. Set Hard Disk Power Down after, Video Power Down after and Auto Suspend to Disabled.
3. Set Power Management Function to Disabled.



When you are using communication software or if sound or voice pauses or skips while played back, disable power management.

## 5. Setup Utility

This chapter describes how to run the Setup Utility to change settings on your computer.

### Running the Setup Utility

With the Setup Utility, you can customize the system configuration information, such as time and date, port assignments, passwords, or power management settings. The information you have specified is saved in a special area called CMOS RAM, which the system reads every time you turn on the computer.

### Contents of the Setup Utility

The Setup Utility consists of five menu pages, as follows:

- Main: Basic system configuration
- Advanced: Device interface configuration (I/O ports, sound settings)
- Security: Password settings
- Power: Power management (battery saving settings)
- Exit: Exit the Setup Utility or return to the default values

### Entering and Exiting the Setup Utility

1. Turn on the computer.
2. When Press <F2> to enter SETUP appears, press F2.
3. Change the desired settings.
4. Press Esc to select the Exit menu.
5. Select one of the exit methods, and press Enter.
6. When the message Setup Confirmation appears, press Enter again. The system restarts.



To turn off the computer when the Setup Utility is open, slide the power switch.

### Using the Setup Utility

To navigate through the different menus, you can use the following keys:

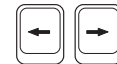

Moves the cursor from one menu to another.



Moves the cursor from one item to another in a menu.

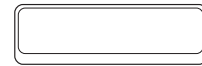

Increases the numeric value or changes an item to the next value.

Space bar



Decreases the numeric value or changes an item to the previous value.



Enters the Exit menu. When a sub-menu is open, this key closes the sub-menu.



Replaces the settings on the current menu with their default values (date and time are not changed).



Restores all the values you previously saved (date and time are not changed).



Displays online help for the Setup Utility.



Displays sub-menu. Items with ► marks contain sub-menus.

## Main menu

**System Time** Defines the system time, using the format hour:minute:second (24- hour format). The Tab key moves the cursor, and the space bar and the "-" key change numerals.

**System Date** Defines the system date. The Tab key moves the cursor, and the space bar and the "-" key change numerals.

**Diskette A** Defines whether to use the floppy disk. To use it, set this item to 1.44MB,3½".

**Hard Disk Type** Specifies the hard disk type. Set to Auto during normal use.

**Boot Sequence** Specifies the sequence in which the boot program looks for operating system files.

**Internal Numlock** Defines whether you can input numerals through keys with blue legends on the built-in keyboard when you connect an external keyboard and lock its numeral keys.

**Memory Cache** Enables or disables the memory cache function that accelerates the access speed to data previously accessed.

**QuickBoot Mode** Enables or disables the quick boot function. When this item is enabled, the system skips certain tests while booting.

**System Memory** shows the size of conventional memory for starting MS-DOS. It always shows 640 KB.

**Extended Memory** Shows the size of extended memory with 1MB or larger.

## Advanced menu

**Serial Port** Sets the RS-232C serial port, selecting the base I/O address. Enabled means that you can select the item yourself. Auto means that the item is automatically assigned. Disabled means that you cannot use the port.

**IR Port** Sets the infrared port, selecting the mode, the I/O channel, the IRQ channel, and the DMA channel. Enabled means that you can select the items yourself. Auto means that all the items except the mode are automatically assigned. Disabled means that you cannot use the port. Set to Auto during normal use.

**Mode** Specifies the IR mode: IrDA or ASK. Set to IrDA during normal use.

**LPT Port** Sets the printer port, selecting the mode and the base I/O address. Enabled means that you can select the items yourself. Auto means that the base I/O address is automatically assigned. Disabled means that you cannot use the port.

**Mode** Specifies the LPT port mode: Bi-directional, Output Only, EPP (Enhanced Parallel Port mode) or ECP (Extended Capabilities Port mode).

**Modem** Sets the built-in modem, selecting the IRQ channel and the I/O channel. Enabled means that you can select the items yourself. Auto means that the items are automatically assigned.

**Sound** Sets the built-in sound controller. MIDI and Joystick do not work in your computer even if set to Enabled or Auto.

**Internal Pointing Device** Enables or disables the glide pad.

**Resolution Expansion** Defines whether the screen is expanded when the resolution is 640x480. Enabled means that the screen is expanded.

**USB Port** Enables or disables the USB port. Always set to Enabled; otherwise, some PC cards may malfunction.

**Plug & Play O/S** Defines whether the operating system supports the plug & play function. Set to Yes during normal use.

**Large Disk Access Mode** Selects the operating system. Set to DOS during normal use. If you use another operating system such as UNIX, select Other.

## Security menu



- See the previous chapter about setting passwords.
- In some password settings, you cannot select some items.

**Set Supervisor Password** Defines the supervisor password up to eight characters.

**Set User Password** Defines the user password up to eight characters. You cannot set the user password unless you have set the supervisor password.



If you lose your password, you will be unable to access the computer or change the configuration. Make sure to select a password you will never forget, or write it down and protect it in a secure place. Otherwise, you will have to contact your dealer for assistance.

**Password on boot** Defines whether the system requires passwords during the boot process. Enabled means that you need to input a password to continue.

**Power Management Security** Defines whether the system requires a password when it resumes from the suspend-to-disk mode. Enabled means that you need to input a password to continue.

**Diskette access** Specifies who can access the floppy disk drive.

**Fixed disk boot sector** Defines whether the boot sector of the hard disk is write- protected. When formatting the hard disk or when reinstalling software, set it to Normal.

## Passwords

Setting a password will help protect against unauthorized access to your computer. When a password is set and the computer is turned on or resumes from the suspend- to-disk mode, the system will require a password.



If you lose your password, you will be unable to access the computer or change the configuration. Make sure you select a password you will never forget, and write it down and save it in a secure place. Otherwise, you will have to contact your dealer for assistance.



If you enter a wrong password three times, the message System Disabled appears. Slide the power switch to turn off the computer, turn it on again, and enter the correct password.

## Supervisor Password and User Password

Two types of passwords limit the access at different levels. To set the user password, you always have to set the supervisor password. When you set the two passwords, a person who knows only the user password has the limitations below:

### When setting items in the Setup Utility

The person who does not know the supervisor password cannot set:

- Set Supervisor Password
- Password on boot
- Power Management Security
- Diskette access
- Fixed disk boot sector

### When the system starts or resumes from the suspend-to-disk mode

If you have enabled Password on boot in the Security menu of the Setup Utility, the system requires a password when you turn on the computer. If you have enabled Power Management Security in the Power menu of the Setup Utility, the system requires a password when the system resumes from the suspend-to-disk mode.



The person who does not know the supervisor password cannot read/write a floppy disk when the item of Diskette access is defined as Supervisor in the Security menu of the Setup Utility.

## Setting the Password

1. In the Security menu of the Setup Utility, select Set Supervisor Password or Set User Password and press Enter.
2. Type your password up to eight characters, and press Enter.
3. Type the same password again, and press Enter.
4. When the confirmation message appears, press Enter.
5. Press Esc and select Exit Saving Changes.
6. Press Enter twice. The system restarts and asks the password you have set.

### If you use the computer personally

We recommend that you set the supervisor password. You can prevent other people from using your computer by enabling Password on boot in the Security menu of the Setup Utility.

### If you share the computer with others

We recommend that a person who administers the computer sets both supervisor and user passwords and lets the other people know only the user password.

## Deleting the Password

1. In the Security menu of the Setup Utility, select the password item you want to delete and press Enter.
2. Type your current password, and press Enter.
3. Without typing any characters, press Enter.
4. Press Enter again.
5. When the confirmation message appears, press Enter.
6. Press Esc and select Exit Saving Changes.
7. Press Enter twice. The system restarts.

## Preventing Infection of Computer Viruses

You can protect against some viruses by limiting writing to the hard disk. To limit writing to the hard disk, set the item Fixed disk boot sector to Write Protect in the Security menu of the Setup Utility.



- You cannot prevent infection of all types of viruses with the above operation.
- Even if a warning message appears, the system may not be infected in some cases.

## Power menu

**Power Switch Function** Defines the function of the power switch. If you select On/Off, the switch works only to turn on/off the computer. If you select Suspend/Resume, the system enters the mode that is specified in the item Suspend Mode when you slide the power switch. To resume the system, slide the power switch again.

**Cover Close** Specifies the mode the system enters when the screen cover is closed.

**Power Management Function** Enables or disables the items below: Hard Disk Power Down after, Video Power Down after, and Auto Suspend.

**Hard Disk Power Down after** Defines the duration of non-access to the hard disk after which the power supply for the hard disk stops automatically.

**Video Power Down after** Defines the duration of non-access to the screen after which the power supply for the screen stops automatically.

**Suspend Mode** Defines which mode the system enters when the system is suspended.

**Auto Suspend** Defines whether the system enters a suspend mode when you do not operate the computer for the specified length of time. This item does not function under Windows 98.

**Critical Battery Suspend** Defines whether the system enters the suspend-to-disk mode when the battery power becomes low.

**Auto Backlight Control** Enables or disables the self-adjustment of the display backlight. When this item is enabled, for example, backlight brightness is reduced when the system operates on battery power.

**Resume On Modem Ring** Defines whether the system resumes from the suspend-to-RAM mode when the modem receives a call.



Modem may not be available in some countries.

**PCMCIA Power when Suspend RAM** Defines whether the system supplies power to the PC card slot when suspended to RAM.

**Battery Level** Shows the amount of battery power remaining. Battery 1 refers to the standard battery; Battery 2 refers to the optional external battery pack.

## Exit menu

**Exit Saving Changes** Saves the settings you have changed and exits the Setup Utility.

**Exit Discarding Changes** Exits the Setup Utility without saving the settings you have changed.

**Load Setup Defaults** Returns the values of all items to default. To exit, select one of the above items.

**Discard Changes** Returns the values of all items to the values you last saved.

**Save Changes** Saves the settings you have changed.

# CHAPTER 2. SPECIFICATIONS

## 1. Specifications

Parts		Specifications
CPU		233MHz MMX technology Pentium Processor using Intel's Mobile Module (frequency differs by configuration)
Secondary cache		Synchronous, PipeLine Burst SRAM (256KB)
ROM		Including system BIOS and VGA BIOS
RAM	System	EDO 64MB
	Video	1.1MB
Display	Panel	Active Matrix (TFT) color LCD
	Video controller	Neo Magic (with Graphics Accelerator)
Keyboard		IBM compatible keyboard
Pointing device		Glide pad (touch-sensitive control pad with 2 buttons)
Drive	Hard disk	IDE interface
	Floppy disk (external)	3.5", 1.44MB/720KB
PC card slot		Type II × 1 (PCMCIA 2.1 compliant) CardBus compliant
Audio system		Microphone, monaural speaker, sound system compliant with Sound Blaster Pro
I/O ports	Audio	Audio output jack, external microphone jack
	Video	External monitor port
	Others	Keyboard/mouse port, USB port, modem jack
	Others (on external floppy disk drive)	Parallel port, RS-232C serial port, keyboard/mouse port
Infrared		IR port (IrDA:115Kbps/1Mbps/4Mbps, SHARP ASK:9600bps)
Modem (may not be available in some countries)		Data: 56Kbps(receive), 33.6Kbps(send), Fax: 14.4Kbps, with voice function
Power	AC adapter	100-240V, 50-60 Hz
	Battery	Rechargeable lithium ion battery
	Battery life	Approximately 2.5 hours (standard battery only) Approximately 8.5 hours (when external battery connected) *battery life may vary depending on usage
	Battery charging time (standard and optional external battery pack)	Turned off/suspended to disk about 5.5 hours Turned on: about 7.5 hours *charging time may vary depending on usage
Dimensions	Computer	10.19" wide × 8.35" deep × 0.84"(min.)/1.12"(max.) high (259mm × 212mm × 21.2mm(min.)/28.3mm(max.))
	Floppy disk drive unit	4.65" wide × 6.81" deep × 0.94" high (118mm × 173mm × 24mm)
Weight	Computer	Approximately 3.19lbs (1.45kg)
	Floppy disk drive unit	Approximately 0.95lbs (4.30g)
Operating environment	Temperature	50°F to 95°F (10°C to 35°C)
	Humidity	20% to 80% (non-condensation)

### Options

**External Battery Pack** CE-BL03

**External CD-ROM Drive Unit** CE-CD01

#### CPU

- Intel MMX Pentium 233MHz processor with 32KB cache memory and math coprocessor.
- Core Voltage: 1.8V, Signal interface: 2.5V, 320pin TCP package

#### System core logic

- Intel 430TX PCIset
- North bridge (System Controller): 82439TX (MTXC), Host to PCI bridge, controls L2 cache and system memory. Core Voltage: 3.3V, 324pin BGA package
- South bridge (PCI to ISA/IDE Xcelerator): 82371EB (PIIX4E), PCI to ISA bridge, controls IDE, USB and Power Management, includes RTC. 3.3V (5V tolerance), 324pin BGA package

#### System memory

- Standard 64MB (Can not be extended)
- 4M × 16 bits type EDO DRAM × 8, 3.3V

#### L2 Cache memory

- Cache memory: 256KB, 32K × 32 bits pipeline burst SRAM × 2. Core Voltage: 3.3V, I/O Voltage: 2.5V, 100pin LQFP package × 2
- TAG RAM: 32K × 8 bits SRAM. Core Voltage: 3.3V, I/O Voltage: 2.5V, 28pin SOJ package

#### Clock Generator

- Microclock MIC1492-02
- Input 14.31813 MHz, Can be controlled by SM bus i/f
- Core Voltage: 3.3V, Output 3.3V & 2.5V, 28pin SSOP package

#### Video Controller

- NeoMagic NM2097
- Includes 1.1MB VRAM, System i/f: PCI, LCD i/f: LVDS

- Resolution and Number of colors

Resolution	Number of Colors
640 × 480	16
	256
	64K
	16M (*1)
800 × 600	256
	64K
1024 × 768 (*2)	256

\* 1: The number of colors in this mode is made using a dithering algorithm.

\* 2: Only 800 × 600 dots are displayed on the internal LCD. Move the cursor to show the remainder of the 1024 × 768 dots.

#### LCD

- Sharp LQ113S1LH01, 11.3" SVGA TFT LCD with 1CCFT backlight
- Resolution: 800 × 600
- Effective viewing area (H × V): 230.4 × 172.8 mm
- Pixel Pitch: 0.288 × 0.288 mm
- Power source: 3.3V, 5V, 12V
- I/F: LVDS

#### LVDS Controller

- NS DS90C363MTD
- 3.3V, 48pin SSOP package

#### PCMCIA Controller

- Ricoh RL5C475A rev.0
- 1 slot PCMCIA Controller, Supports 16bit card, Card bus card, ZB port.
- 3.3V, 144pin LQFP package
- Power Switch: Micrel MIC2562A-1BM(3.3V, 5V, 12V, 14pin SOP package)

#### HDD

- Hitachi 2.5" 3.2GB HDD DK237A-32
- 5V i/f, 9.5mm H

#### BIOS

- SST 28SF040 4Mbits Flash EEPROM
- Includes System, Video, PnP and APM.
- 5V, 32pin PLCC package

#### Keyboard Controller

- Mitsubishi M38813
- Support 2 PS/2 ports and 1 Touch pad.
- 5V, 64pin TQFP package

#### Keyboard

- Sejin 81 keys keyboard for US, 82 keys for Europe
- IBM 101/102 keys compatible keyboard
- Supports 2 windows keys
- 17mm pitch, 2.5mm stroke

#### Touch Pad

- Alps Glide pad
- PS/2 mouse compatible
- 2 click buttons
- Resolution (X × Y): 290 ± 30 × 255 ± 30 cpi
- Supports IntelliMouse scroll function.
- Automatically disabled when external mouse is connected.

#### I/O controller

- NS PC97338VJG
- Controls Serial port, Parallel port, IR port and FDD.
- 5V, 100pin TQFP package

#### RS232C driver/Receiver

- Harris HIS213
- 5V, 28pin TSOP package

#### FDD

- Mitsubishi 3.5" FDD MF355H
- 5V i/f

#### Audio Controller

- Crystal CS4237B
- Sound Blaster, Sound Blaster Pro, Windows Sound System compatible
- Full duplex operation
- Controls Modem Chipselect
- 5V, 100pin TQFP package
- ZB port buffer: Crystal CS4331, 5V, 8pin SOP package

#### Modem Controller (may not be available in some countries)

- PCtel Software Modem PCT388T
- Supports K56Flex.
- 5V, 100pin TQFP package
- CODEC: SGS STLC7546, 5V 44pin TQFP package

#### Embedded Controller

- Hitachi 1chip micro controller H8
- Controls Power Sequence, Battery Charge, SM bus for Battery Gage.
- 5V, 100pin QFP

#### DC/DC Controller

- V5S(5V), V3S(3.3V): Toyota SB3052P, VAB(Battery or AC adapter), 28pin SSOP
- VCPUCORE(1.8V): Toyota SB3030, VAB(Battery or AC adapter), 16pin SOP
- VPP(12V): Linear Tech. LT1301, V5S(5V), 8pin SOP

#### Regulator

- VCPUIO(2.5V):Micrel MIC2951BU, V3S(3.3V), 5pin
- VMCU(4.7V): NS LP2951CM, VAB, 8pin SOP
- V3(3.1V): Trex XC62FP3102M, VMCU, 3pin

#### Battery Charger

- Linear Tech. LT1511
- 22V, 24pin SOP package

#### Battery

- Li-ion Battery  
Internal: Panasonic 3.7V × 1400mAh × 4cells (4 series)  
External: Panasonic 3.7V × 1500mAh × 8cells (4 series, 2 parallel)
- Battery Gauge: Banchmarq BQ2092
- Li-coin battery for CNOS backup: Hitachi Maxell CR2032, 3V, 220mAh

#### AC adapter

- SAMSUNG 22V 1.8A AC Adapter
- Input Voltage: 100-240VAC, Input Frequency: 50/60Hz

# CHAPTER 3. DISASSEMBLY AND REASSEMBLY

1. Here is the procedure for disassembling the PC-A100. The product should be reassembled in the reverse order from disassembly.
2. The description of some components that can be disassembled and reassembled relatively easily may be omitted.
3. Before trying to disassemble the product, make sure of the wiring and the positions of the tapes and Mylars attached.

## 1 Keyboard, LCD unit

- a. Remove the keyboard unit (4), upper cabinet (5), and LCD unit (14) from the lower cabinet (15), following the flow chart.

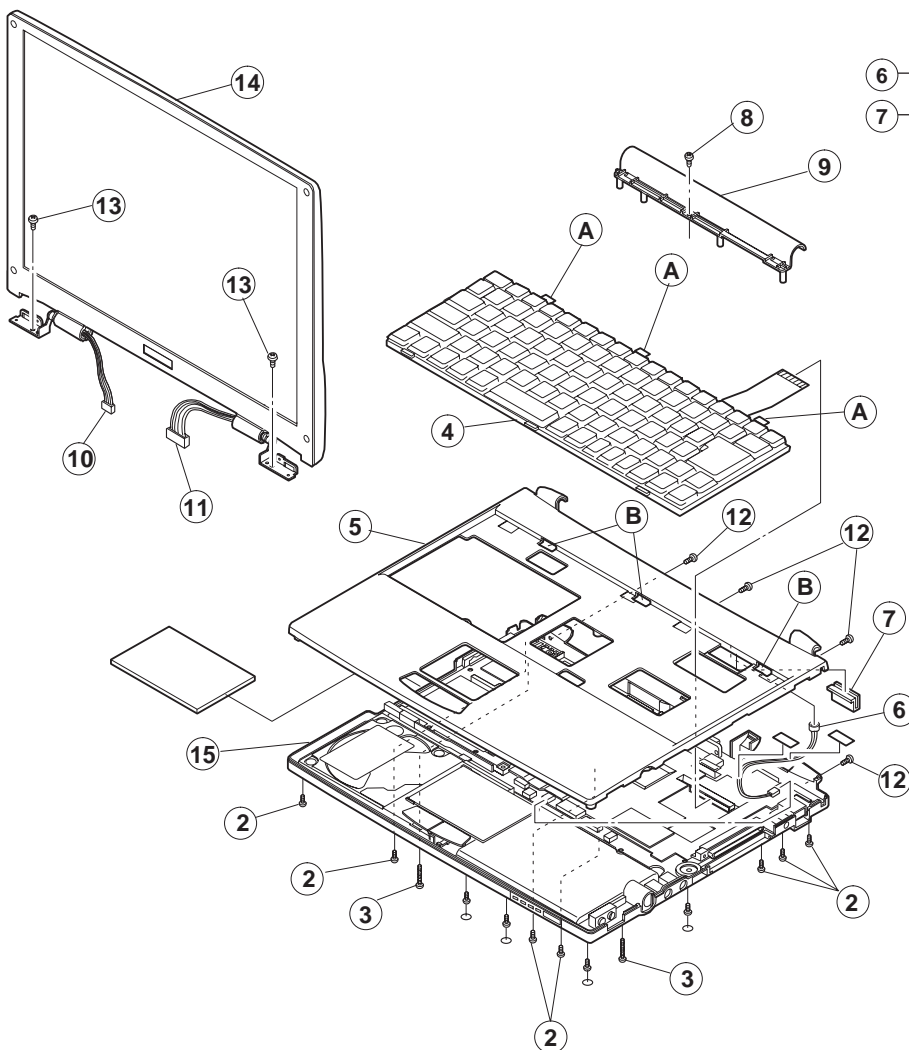

### Parts List

No.	Part Name	Q'ty
2	Screw (M2 × 5)	8
3	Screw (M2 × 8)	2
4	Keyboard unit	1
5	Upper cabinet	1
6	Mike unit	1
7	Key-reinforcement angle	1
8	Screw (M2 × 6)	1
9	Indicator cover	1
10	Indicator cable	1
11	LCD cable	1
12	Screw (M2 × 5)	4
13	Screw (M2 × 4)	2
14	LCD unit	1
15	Lower cabinet	1

### [Cautions for reassembling]

1. The inverter cable (10) should be wired by pushing it in the direction indicated by the arrow.
2. For the installation of the key-reinforcement angle, see the figure below.

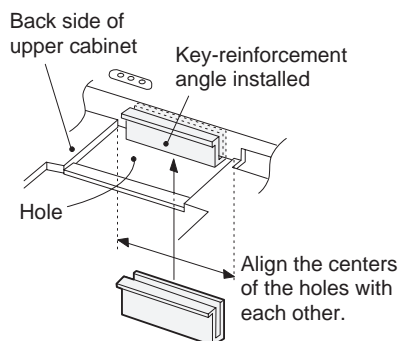
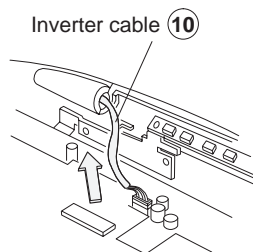

3. When installing the keyboard unit (4), align the projection of the unit (item A) with the recess in the upper cabinet (item B).

## 2. Inverter PWB, LCD unit

- Remove the LCD unit from the lower cabinet, following the procedure 1-a.
- Remove the LCD panel ④, inverter PWB ⑩, and LCD unit ⑪, following the flow chart.

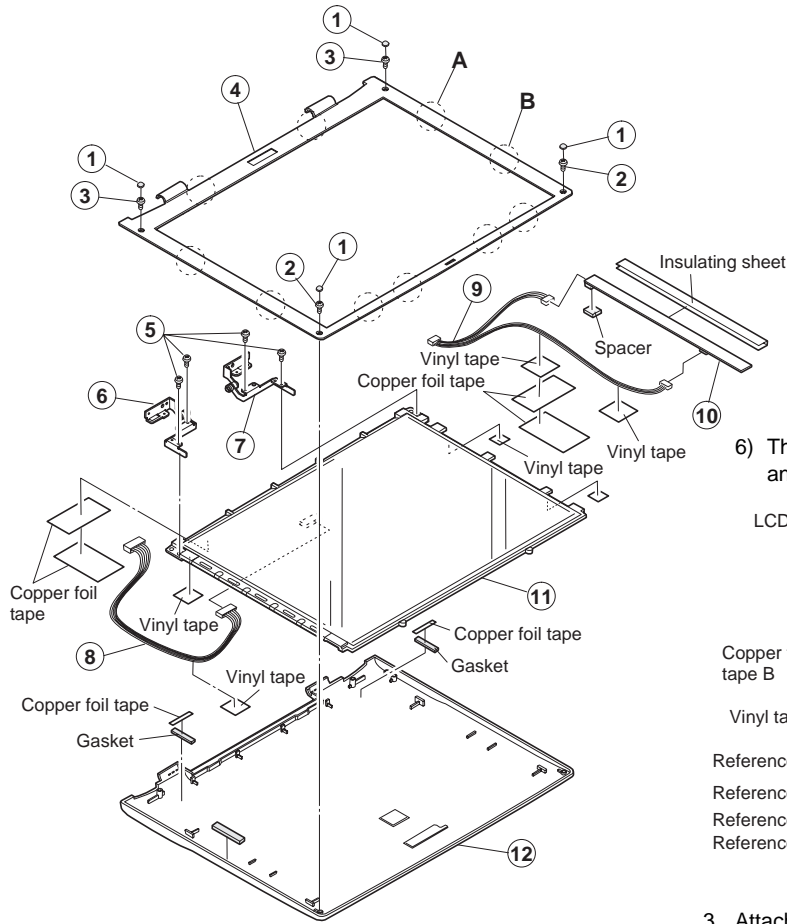

### Parts List

No.	Part Name	Q'ty
1	Screw-covering sheet	4
2	Screw (M2 × 2.8)	2
3	Screw (M2 × 6)	2
4	LCD panel (display front cabinet)	1
5	Screw (M2 × 6)	4
6	Hinge R	1
7	Hinge L	1
8	Main cable	1
9	Inverter cable	1
10	Inverter PWB	1
11	LCD unit	1
12	LCD cover assembly	1

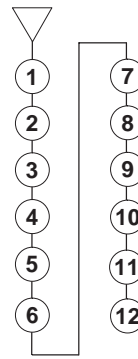

- The main cable should be passed to the left side of the rib A and the inverter cable to the right side of the rib B.

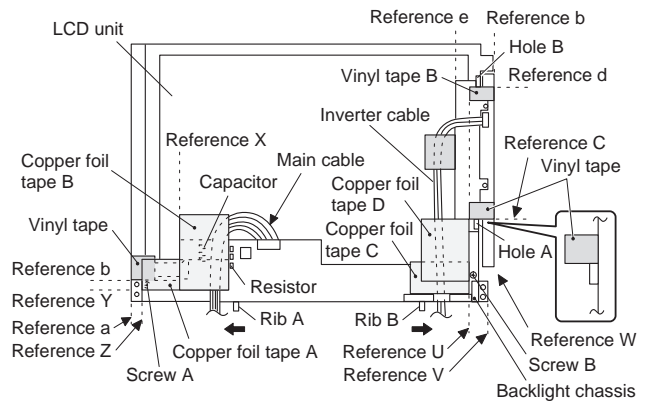

- Attach the insulating sheet and inverter spacer to the inverter PWB, using the following cautions:

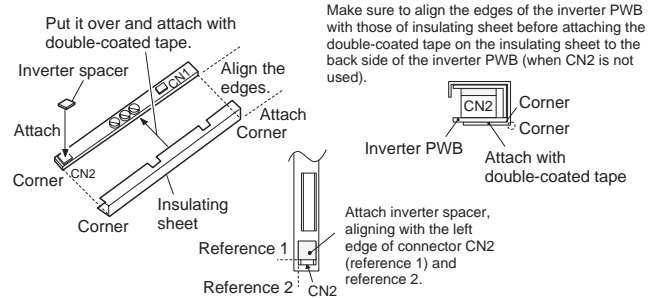

- Use caution not to get the high-voltage cable caught when tightening the screw for the hinge L ⑦.

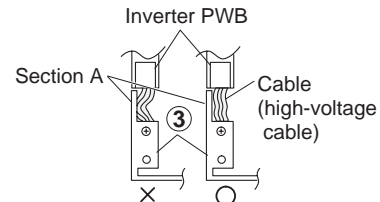

### [Cautions for reassembling]

- Attach two gaskets to the LCD cover assembly ⑫ using the following references:

- After attaching the gaskets (40 mm) aligning with references A and B, attach the copper foil tape to the gasket, aligning the center of the foil tape with the center of the gasket.

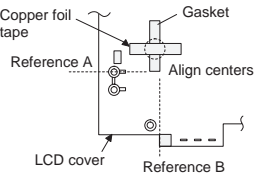

- After attaching the gasket (40 mm), aligning with references A and B, attach the copper foil tape to the gasket, aligning the center of the tape with the center of the gasket.

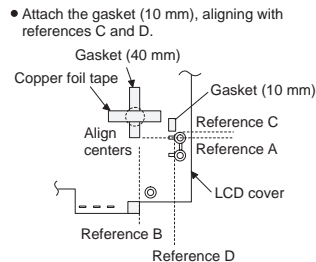

- The LCD unit should be wired as follows:

- After attaching the vinyl tapes, attach four copper foil tapes in the order of A to D.
- Make sure to attach the copper foil tape A to the screw A.
- Make sure to attach the copper foil tape C to both the screw B and backlight chassis.
- Use caution not to block the holes A and B when attaching vinyl tapes A and B.
- Make sure to pass the main cable between the capacitor and the resistor.

### 3. Lower cabinet (No. 1), built-in battery replacement

- Remove the keyboard, upper cabinet, and LCD unit from the lower cabinet, following the procedure 1-a.
- Remove the built-in battery, HDD unit assembly, and glide point PWB, following the flow chart.

[Note] When replacement of built-in battery is required, follow the steps ① to ⑩ of the flow chart.

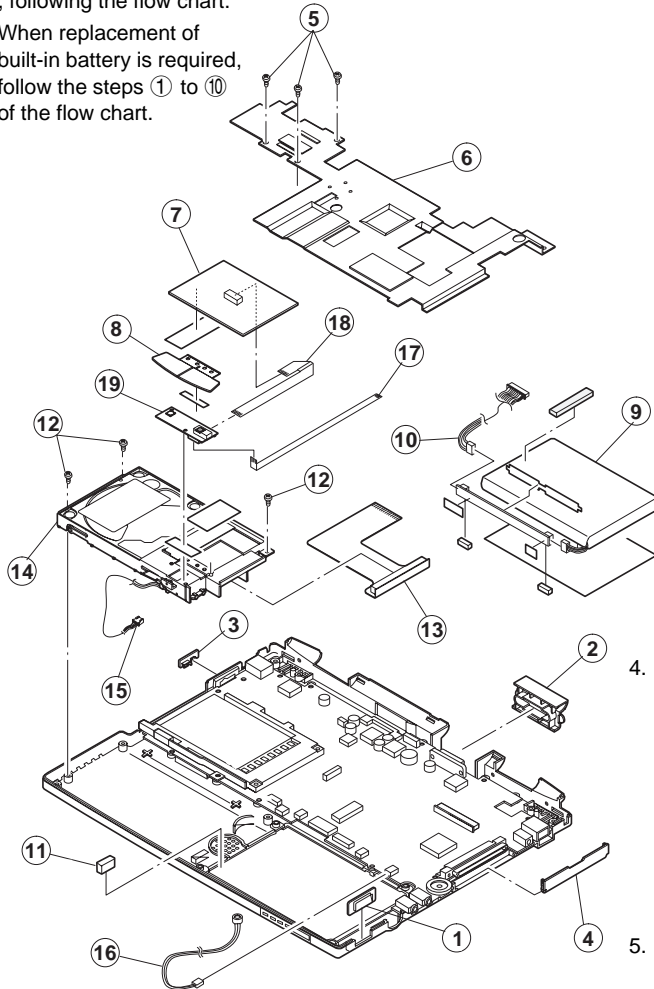

#### Parts List

No.	Part Name	Q'ty
1	IR filter	1
2	D-sub connector cover	1
3	Power supply switch button	1
4	IO connector cover	1
5	Screw (M2 × 8)	3
6	Heat dissipation plate assembly	1
7	Glide point pad assembly	1
8	Glide point button	1
9	Built-in battery	1
10	Power supply cable	1
11	Glide PWB supporting material	1
12	Screw (M2 × 4)	1
13	HDD FPC	1
14	HDD unit assembly	1
15	Shut switch cable	1
16	Mike cable	1
17	Glide point FPC (fine)	1
18	Glide point FPC (thick)	1
19	Glide point PWB	1

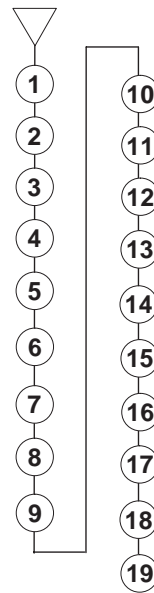

- Connect the HDD FPC ⑬ to the rightmost pin of the HDD.

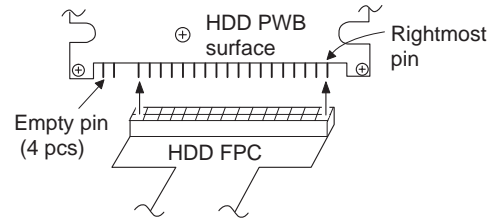

- The shut switch cable ⑮ and mike cable ⑯ should be wired as shown below.

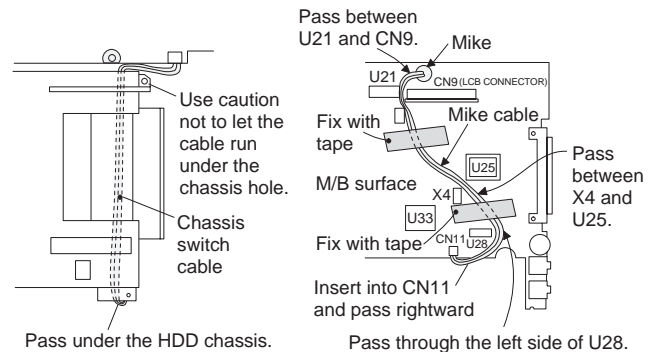

#### [Cautions for reassembling]

- Attach the glide point-covering sheet to the glide point PWB ⑲, using the following references:

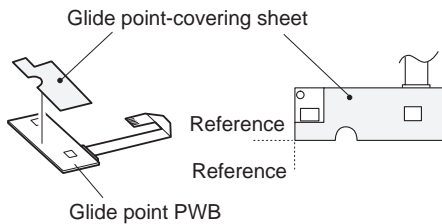

- Bend the FPCs as shown in the figure on the right, when replacing the glide point FPC (fine) ⑰ and the glide point FPC (thick) ⑱.

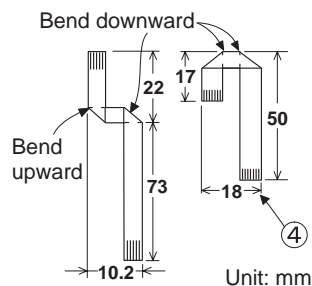

- When replacing the glide point FPC (fine) ⑰ and glide point FPC (thick) ⑱, bend them as shown in the figure on the right. 3.
- Connect the shut switch cable ⑮ to the main PWB CN23 before installing the HDD unit ⑭.

- Connect glide point FFC (large) to glide point pad assembly ⑦. Install glide point pad assembly ⑦ to HDD chassis.
- Install power supply switch button ③ as shown below. 4

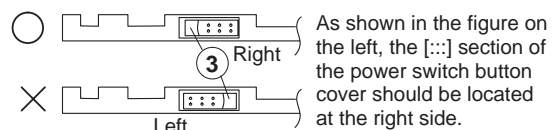

As shown in the figure on the left, the [:::] section of the power switch button cover should be located at the right side.  
Make sure the button is inserted in parallel to the cabinet. (Otherwise, the rib might be broken leading to poor sliding of the button.)

## 4. Lower cabinet (No.2)

- Remove the keyboard, upper cabinet, and LCD unit from the lower cabinet following the procedure 1-a.
- Remove the built-in battery, HDD unit and others, following the procedure 3-b.
- Remove the lithium battery, speaker, IR-PS PWB and main PWB, following the flow chart.

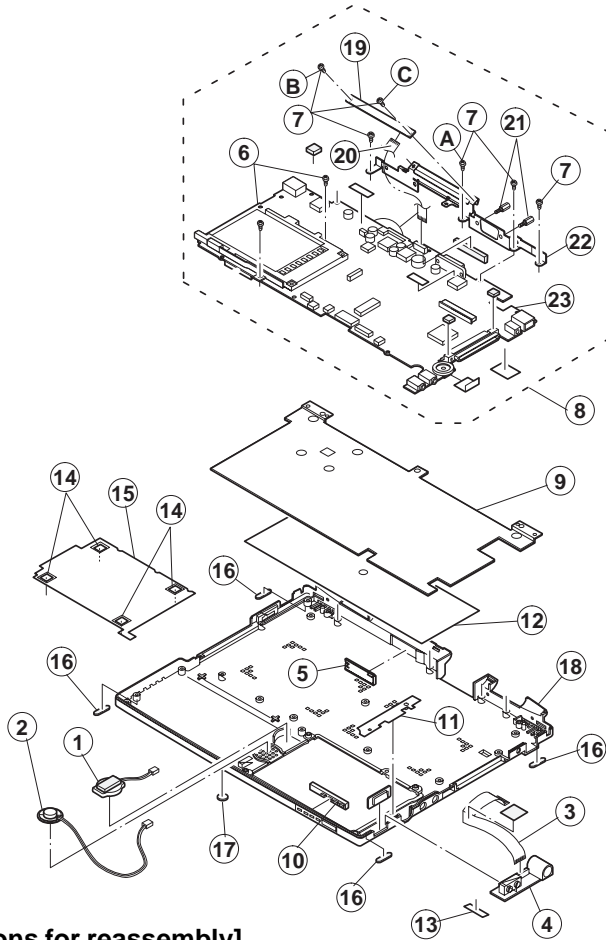

## Parts List

No.	Part Name	Qty
1	Lithium battery	1
2	Speaker	1
3	FFC (for IR-PS PWB)	1
4	IR-PS PWB	1
5	Expansion battery connector cover	1
6	Screw (M2 × 2.8)	2
7	Screw (Ms × 4)	6
8	Main PWB assembly	1
9	Heat dissipation plate assembly	1
10	Battery indicator lens	1
11	IR PWB insulating sheet	1
12	Heat dissipation hole sheet	1
13	Reset label	1
14	HDD cushion	1
15	HDD insulating sheet	1
16	Rubber leg (oval)	4
17	Rubber leg (circle)	1
18	Lower cabinet	1
19	LED PWB	1
20	LED FFC	1
21	Hex. screw	2
22	Connector angle	1
23	Main PWB	1

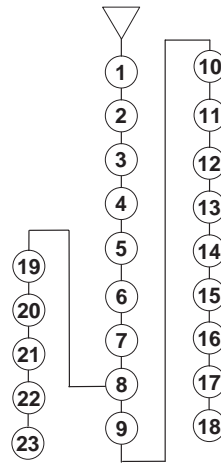

### [Cautions for reassembly]

- Attach the gaskets (2 at FDD side, 1 at Audio side) to main PWB ⑳ using the following references.

(FDD side)

(Audio side)

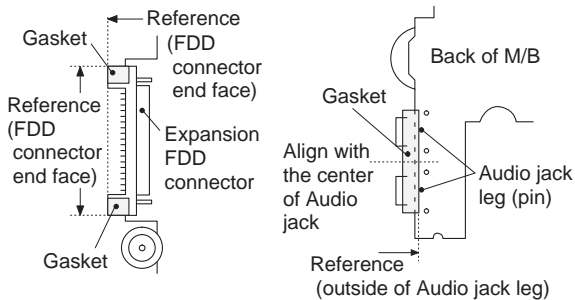

- Attach the two insulating sheets to main PWB ㉓ using the following references.

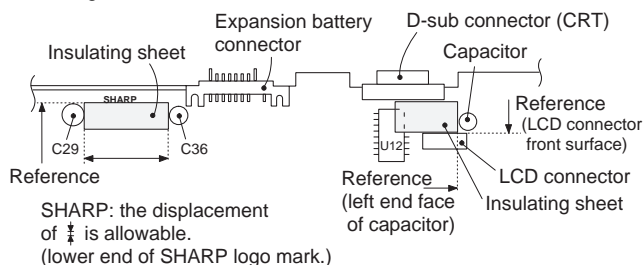

- Attach the heat dissipation sheet ⑫ using the following references.

Align the heat dissipation sheet hole with the boss hole in the lower cabinet and attach the heat dissipation sheet so that the sheet is parallel to the left end surface of the lower cabinet.

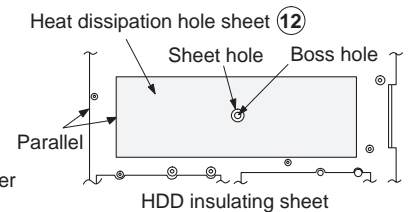

- Attach HDD insulating sheet ⑮ to HDD cushion ⑭ using the following references.

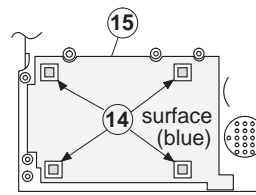

(Note)  
HDD cushion must be attached using double-coated tape. Do not peel off the vinyl (blue) from the surface.

[Note] HDD cushion must be attached using double-coated tape. Do not peel off the vinyl (blue) from the surface.

- Attach IR insulating sheet ⑪ as shown in the figure on the right.
- When setting main PWB assembly ⑧ to the lower cabinet, insert the knob and audio jack first.
- Secure the main PWB assembly ⑧ with 6 screws. The screws should be tightened in the order of A to C. Use caution not to damage LCD FFC.

Attach I/R PWB insulating sheet, using rib A as a reference.

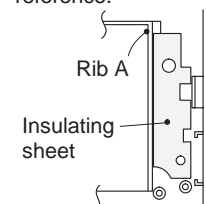

# CHAPTER 4. PRECAUTIONS

## FDD/HDD/CD-ROM

### (Precautions when unpacking the package)

1. Be careful not to expose unit to any physical shock since it is a precision instrument. (do not give it a shock equivalent to or exceeding a drop from the height of 70 cm in a packed condition)
2. Be sure workers and their cloths are not charged with electricity when they handle the parts. (be sure they wear a grounding band)
3. Packing must be done under the following conditions: (same conditions apply to the assembling)

Temperature (°C)	Humidity (% RH)	Temperature change (°C/H)
10 ~ 40	20 ~ 80	20

- \* When the temperature is low, do not forget to take measures against static electricity.
  - \* Temperature change means the difference in temperature between before and after the unpacking.
4. Be sure not to pile up precision instruments by themselves but to place each of them on a stable and non-shocking underlay. (be sure to keep the board surface down)

### (Storage)

#### ◆ Storage method common in servicing and in packed condition

1. Be sure to store it in the following conditions:

Temperature (°C)	Humidity (% RH)
-16 ~ 60	20 ~ 80

- \* Do not store in a car in summer.
- \* When the temperature is low, do not forget to take measures against static electricity.

#### ◆ Storage method in servicing

1. When parts are stored alone, they should be covered. (be sure to take measures against dust)
2. Be sure to take measures against static electricity. (Place the part on a mat which prevent static electricity)
3. Do not pile up the parts. (also be sure not place any other part on a part)

#### ◆ Storage method in packed condition

1. Regardless the length of the storage period, store it in the same condition as it is originally packed and delivered.

### (Handling)

1. Do not forget to wear a grounding band when working on unit.

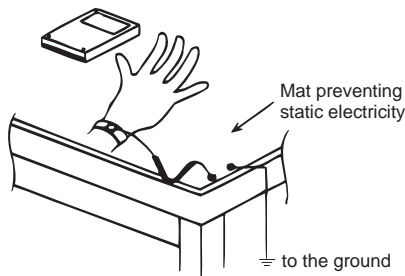

- \* Confirm with a tester when you put the grounding band (1MΩ ~ 10MΩ) on. A grounding wire should be installed at an appropriate location.

2. For any unit, do not stack in piles.

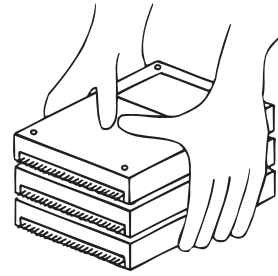

3. Avoid any impact with the unit.

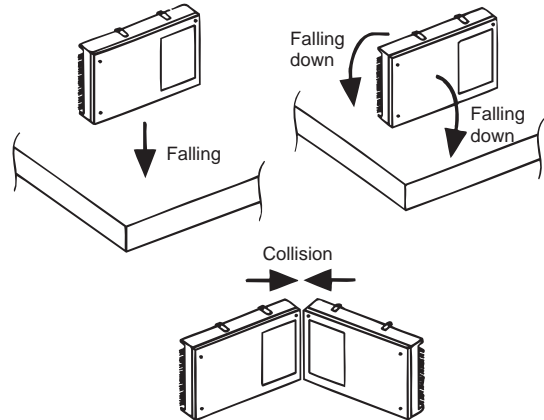

- \* Be sure not to use the unit(s) if they were subject to any physical shock.

4. Hold the units by the side.

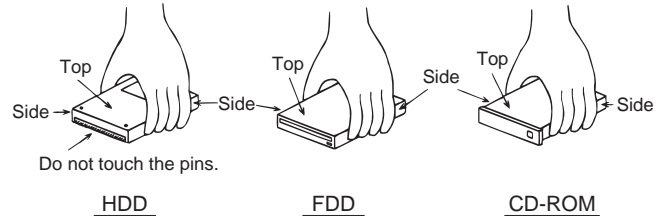

5. Use designated torque/tools (low impact drivers)
6. Keep magnetic materials away from the unit.

### Precaution when handling FDD

1. Do not press the top surface of FDD.

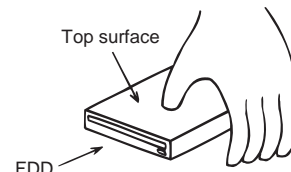

### Precautions when handling CD-ROM drive

1. Be sure not to touch the object lens.
2. Be sure to keep dust and dirt away from the object lens.

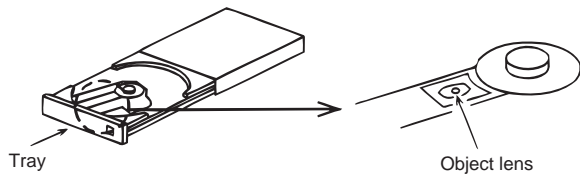

\* If the object lens is stained with dust and/or dirt, remove them with one of the following methods:

- Blow the dust with an airgun.
- Use Hitachi-Maxell's CD-ROM lens cleaner.
- Wipe the lens gently with an applicator using Nippon Applicators' CD lens cleaner liquid B4.

3. Do not press the top surface of CD-ROM drive.

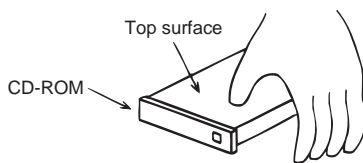

4. Do not pull the tray by force.
5. Do not apply any upward, downward, leftward or rightward force to the tray.
6. Be sure to insert a CD-ROM by pressing it in the middle.

### Precaution on HDD

1. Cable connection/disconnection and transfer of HDD shall be performed after the unit is left untouched for more than 15 seconds after the power supply is turned off (a state where the motor of HDD has been stopped or green/red light has been on).

# CHAPTER 5. RE-INSTALLATION

## Re-installation Instructions for PC-A100 Series

### Preparation for Re-installation

You can format the hard disk and re-install the preinstalled software with the recovery CD-ROM, and set the status of your computer to the same configuration as shipped from the factory. Necessary for re-installation are the following:

- Optional external CD-ROM drive (SHARP CE-CD01)
- Product Recovery CD-ROM
- Floppy disks or other external media for data backup
- Getting Started Microsoft Windows 98 manual

Unless otherwise specified, the instructions in this booklet assume that you use SHARP CE-CD01 CD-ROM drive.



- It will take about 30 minutes to complete the re-installation. The time depends on the data transfer rate of the CD-ROM drive.
- It takes about five seconds for the system to recognize a CD-ROM. If you operate too quickly, an error message may appear. In this case, return to the first step and repeat the installation.
- Use the Product Recovery CD-ROM only for your computer.
- Unless otherwise specified, the instructions in this booklet assume that you are installing Windows 98 into the C:\WINDOWS directory.



In the re-installation procedures, use only AC power. If you use the battery and the battery power becomes low, you cannot continue the re-installation.

### Backing up the data

Before formatting the hard disk, you should back up your data. For details on how to back up your data, see the Windows Online Help.



Although the pointer may be shown on the screen, never touch the keyboard or the glide pad during recovery except when the message prompts you to.

### Formatting the hard disk and reinstalling Windows 98 and other programs

1. If any peripheral devices, except the external floppy disk drive and the CD-ROM drive, are connected to your computer, disconnect them. See Chapter 4 of the Operation Manual.
2. Connect the external CD-ROM drive to the computer and turn it on.
3. Turn on the computer.
4. When the message Press <F2> to enter Setup appears, press F2. The Setup Utility opens.
5. Insert the Product Recovery CD-ROM into the CD-ROM drive.
6. In the Exit menu, select Load Setup Defaults; then, press Enter twice.
7. Set the items in each menu as follows:

#### Main

Boot Sequence: Set 1 to Option CD-ROM Drive

#### Power

Power Management Function Disabled

8. Press Esc; then, Enter twice. The system restarts.
9. Read the message and press Enter.
10. Follow the instruction on the screen.
11. After the hard disk is recovered, remove the Product Recovery CD-ROM and press any key. The system restarts.
12. Set up Windows 98, following the instructions on the screen.
13. After the setup is completed, select Shut Down from the Start menu.
14. In the Shut Down Windows dialog box, select Restart; then, Yes. The system restarts.
15. When the message Press <F2> to enter Setup appears, press F2. The Setup Utility opens.
16. In the Exit menu, select Load Setup Defaults; then, press Enter twice.
17. Make sure the item Exit Saving Changes is highlighted and press Enter twice. The system restarts, and recovery is completed.

# CHAPTER 6. BLOCK DIAGRAM

## PC-A100 Block diagram

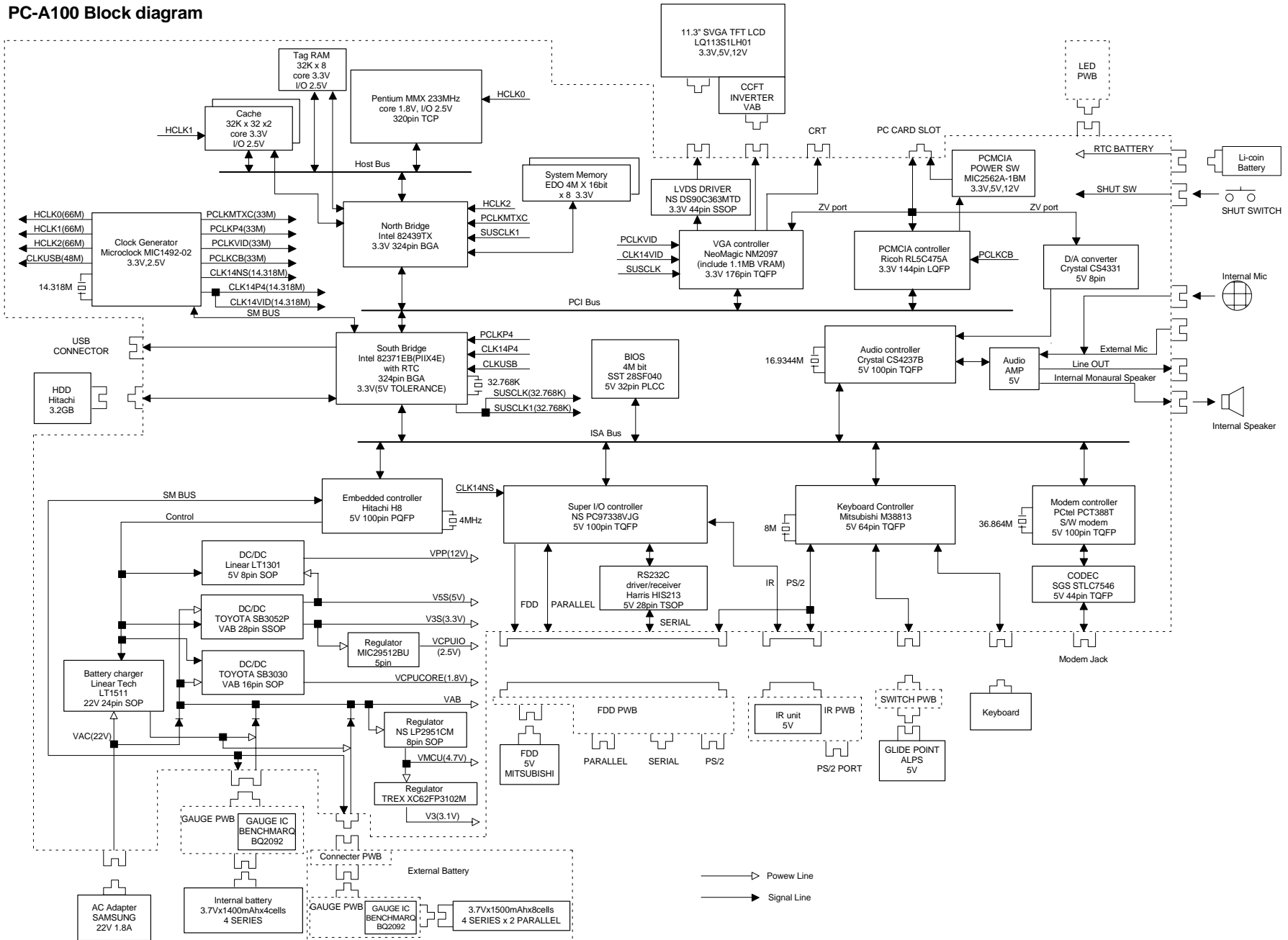



A100U,Y,C,A I/O TO CPU CONNECTOR (REV 1.E)

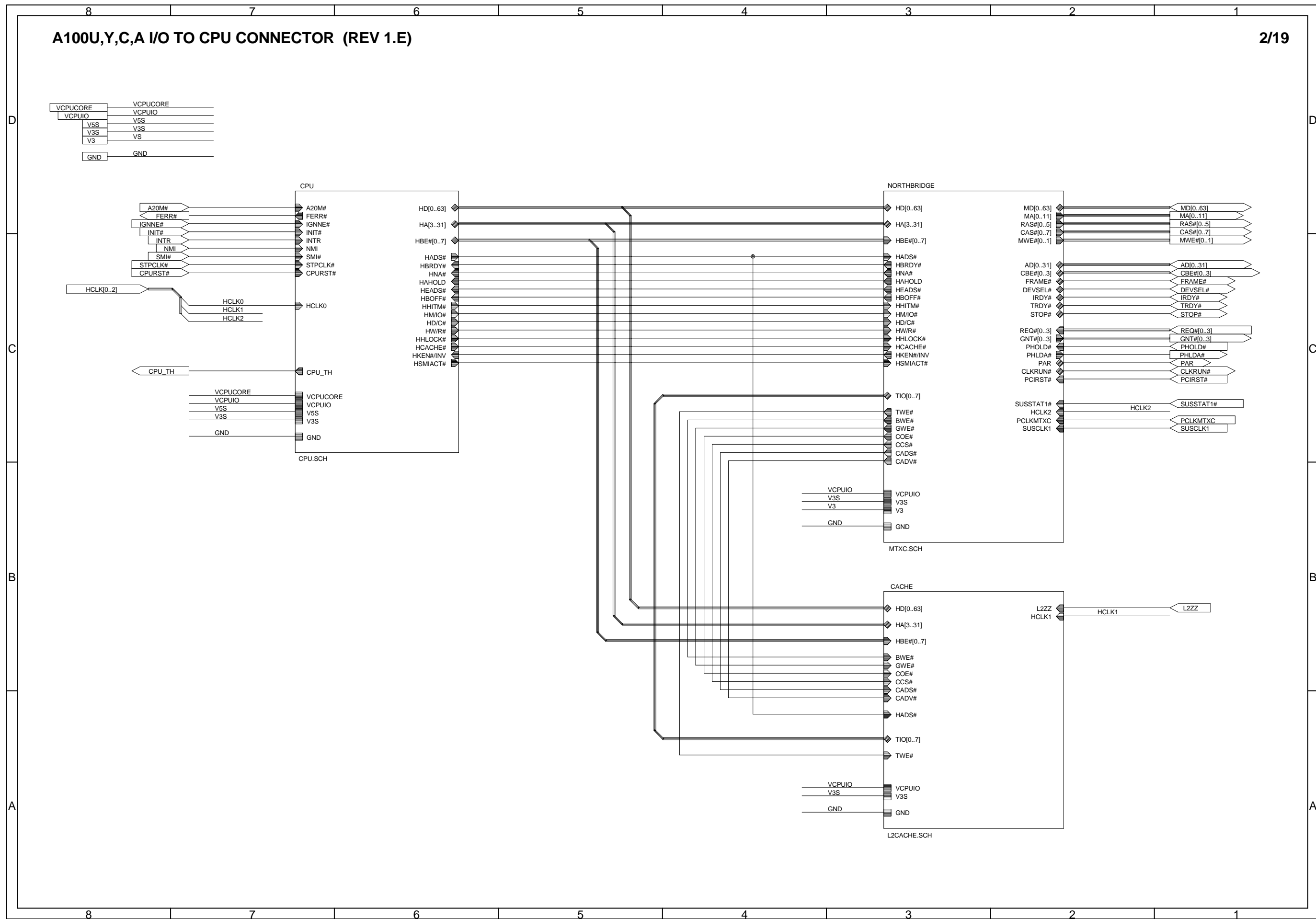

# A100U,Y,C,A TILLAMOOK (REV 1.E)

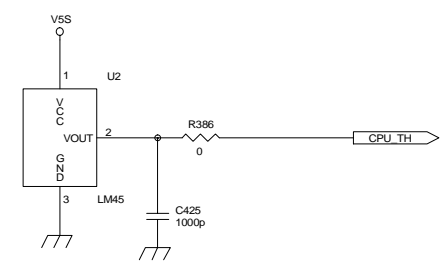
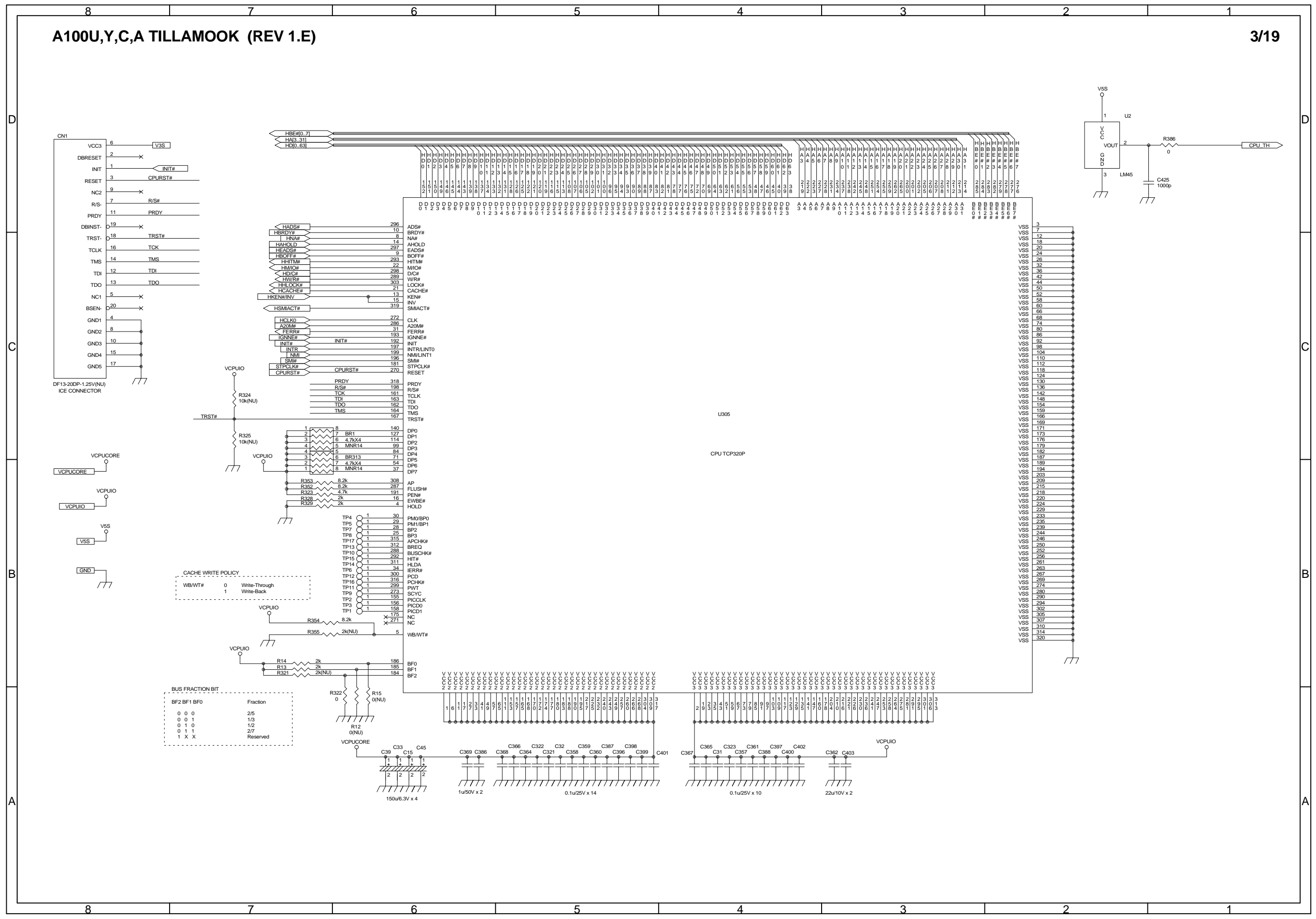

CACHE WRITE POLICY

WBWT#	0	Write-Through
	1	Write-Back

BUS FRACTION BIT

BF2 BF1 BF0	Fraction
0 0 0	2/5
0 0 1	1/3
0 1 0	1/2
0 1 1	2/7
1 X X	Reserved

A100U,Y,C,A Northbridge (REV 1.E)

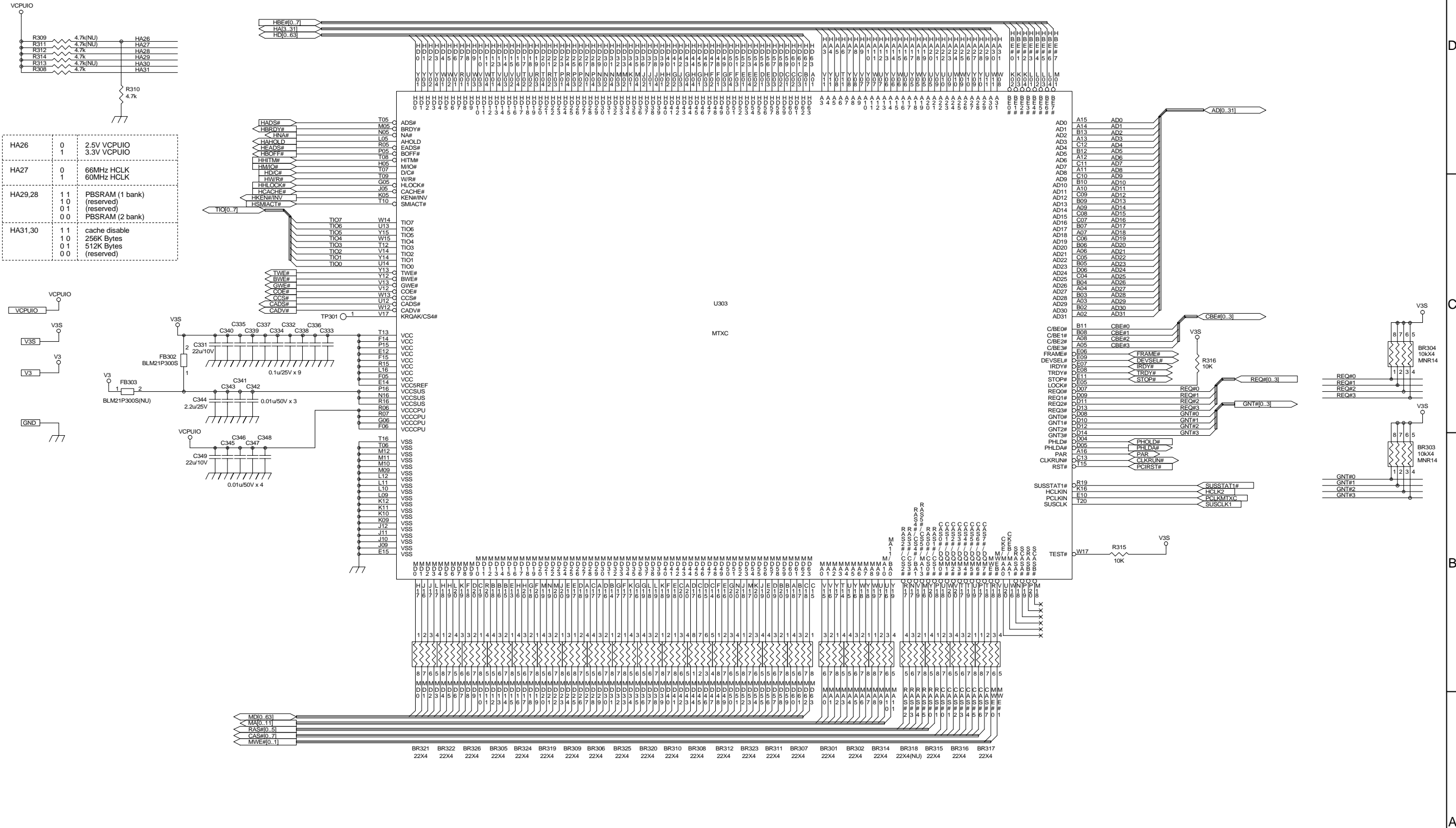

A100U,Y,C,A CACHE AND TAG SRAM (REV 1.E)

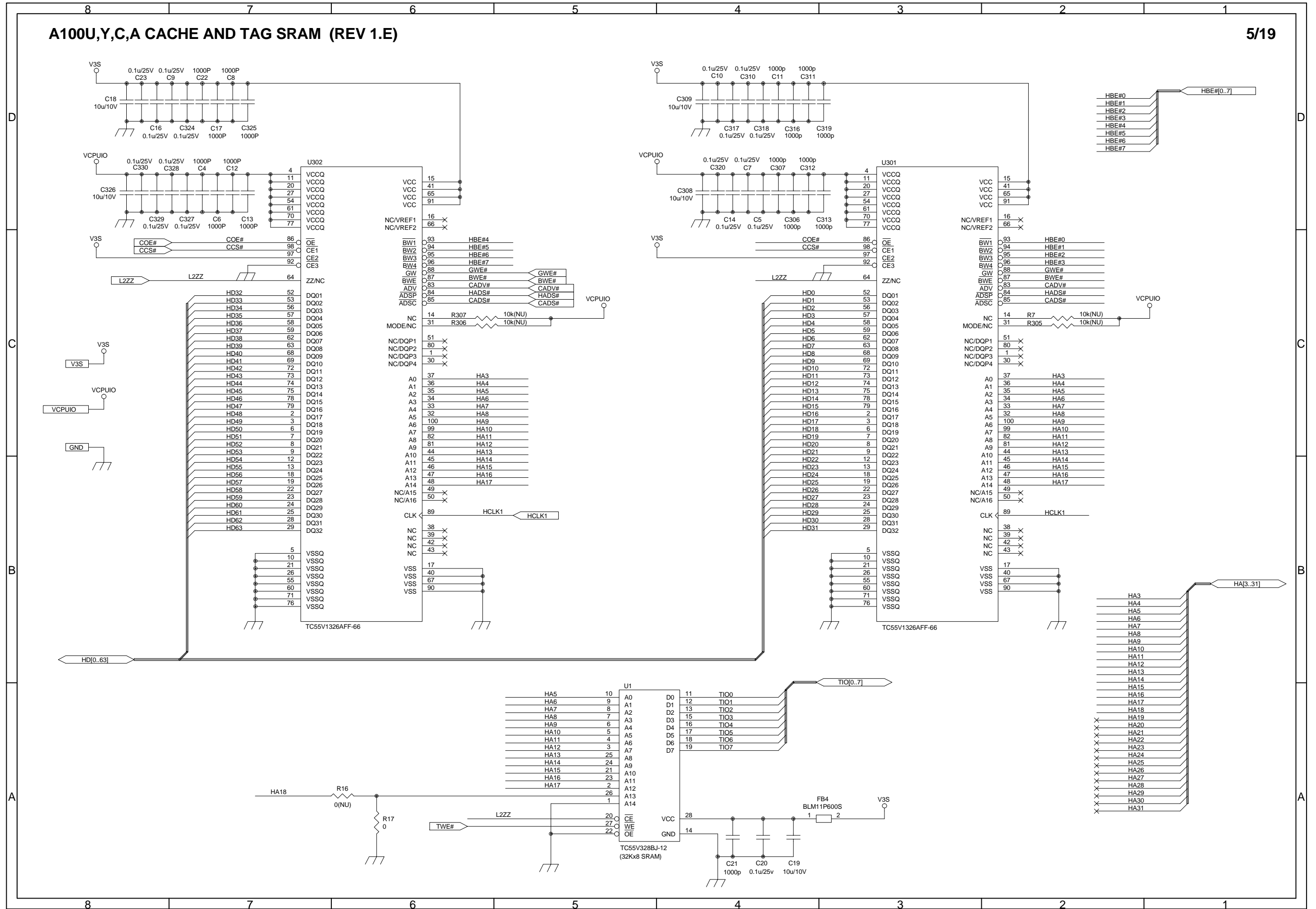

# A100U,Y,C,A MAIN MEMORY EDO 64MB (REV 1.E)

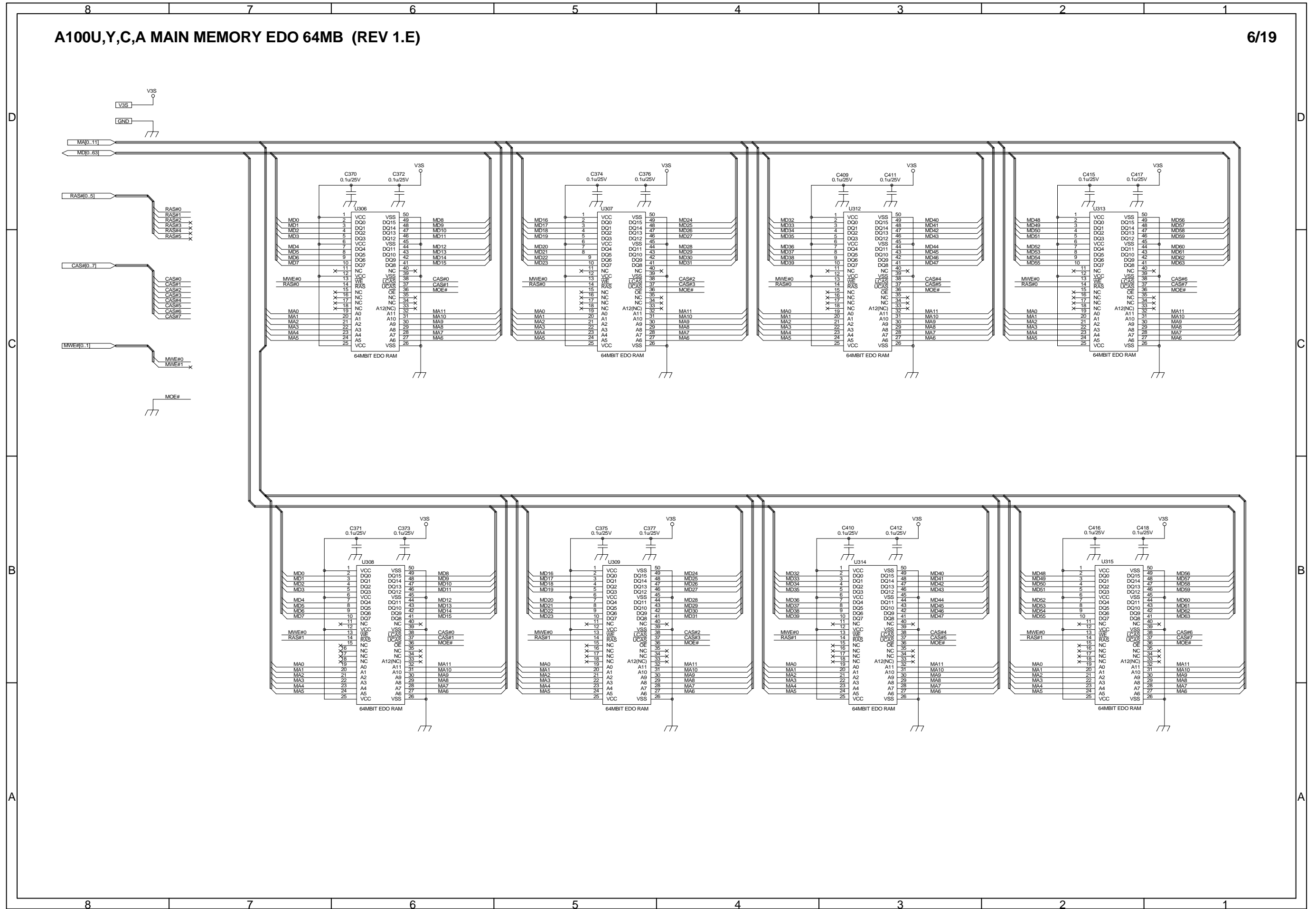

# A100U,Y,C,A South Bridge (PIIX4E) (REV 1.E)

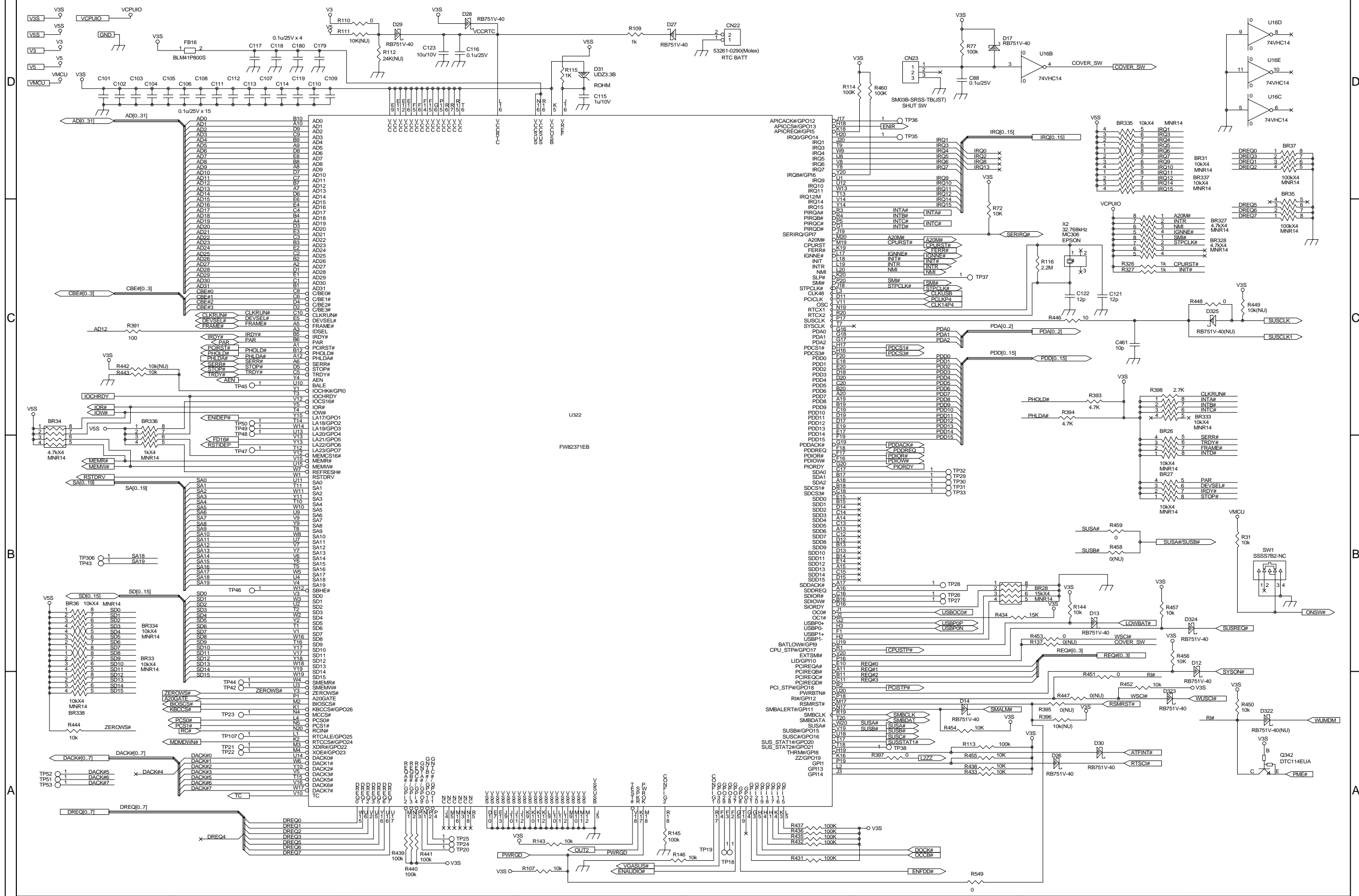

# A100U,Y,C,A CLOCK GENERATOR AND DRIVER (REV 1.E)

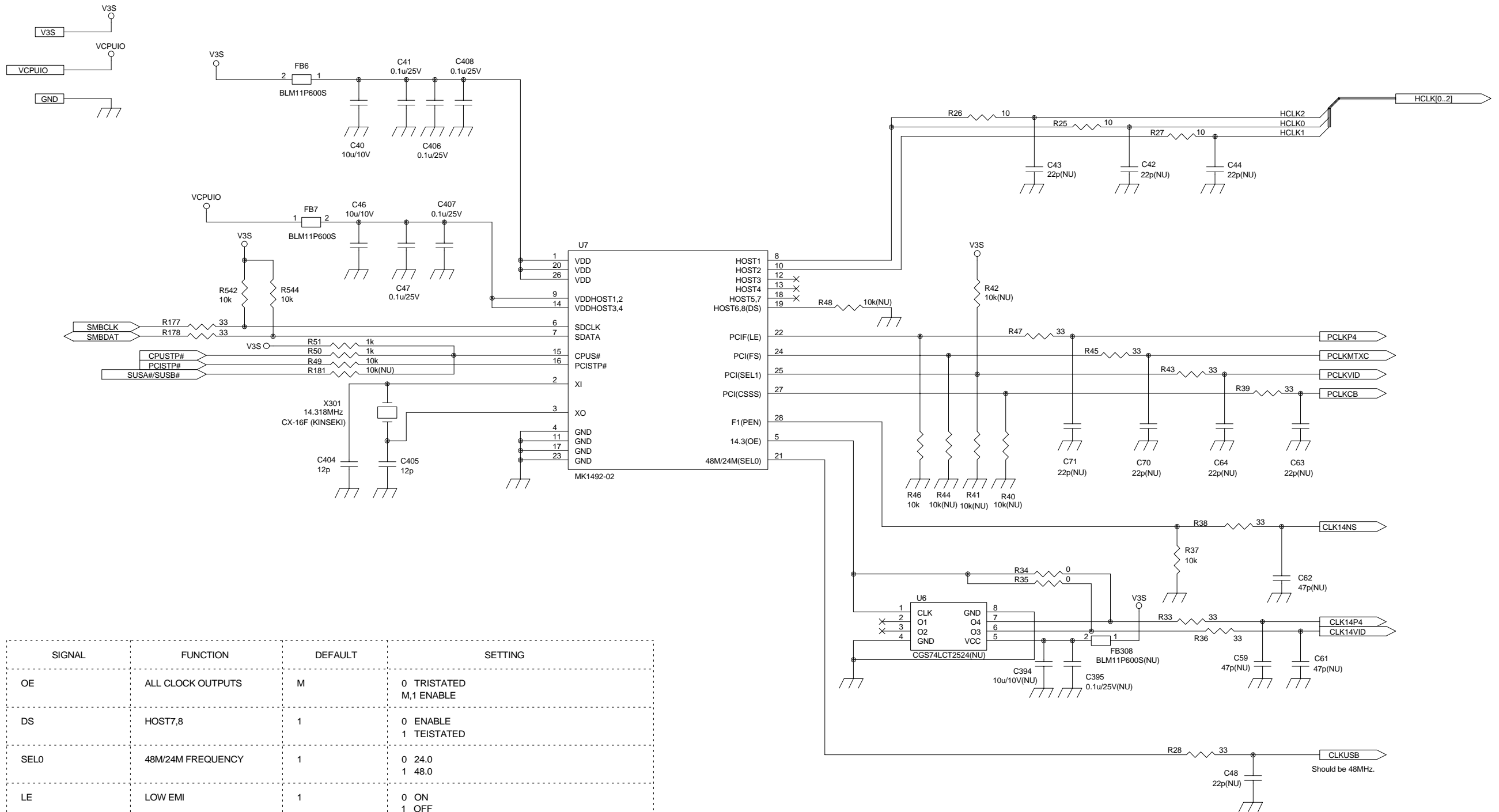

SIGNAL	FUNCTION	DEFAULT	SETTING
OE	ALL CLOCK OUTPUTS	M	0 TRISTATED M,1 ENABLE
DS	HOST7,8	1	0 ENABLE 1 TEISTATED
SEL0	48M/24M FREQUENCY	1	0 24.0 1 48.0
LE	LOW EMI	1	0 ON 1 OFF
CPUS#/CSSS/FS	HOST/PCI FREQUENCY	1/1/1	1/X/0 60.0(OE=M) 50.0(OE=1) 1/X/1 66.6(OE=M) 75.0(OE=1) M/0/X 33.33(OE=M) 33.33(OE=1)
SEL1	F1 FREQUENCY	M	0 PCI M 14.318 1 24.0
PEN	PCIF ENABLE	M	0 Pin25=PCI Pin24=PCI M Pin25=PCI Pin24=PCIF 1 Pin25=PCIF Pin24=PCIF

# A100U,Y,C,A PCMCIA CONTROLLER (REV 1.E)

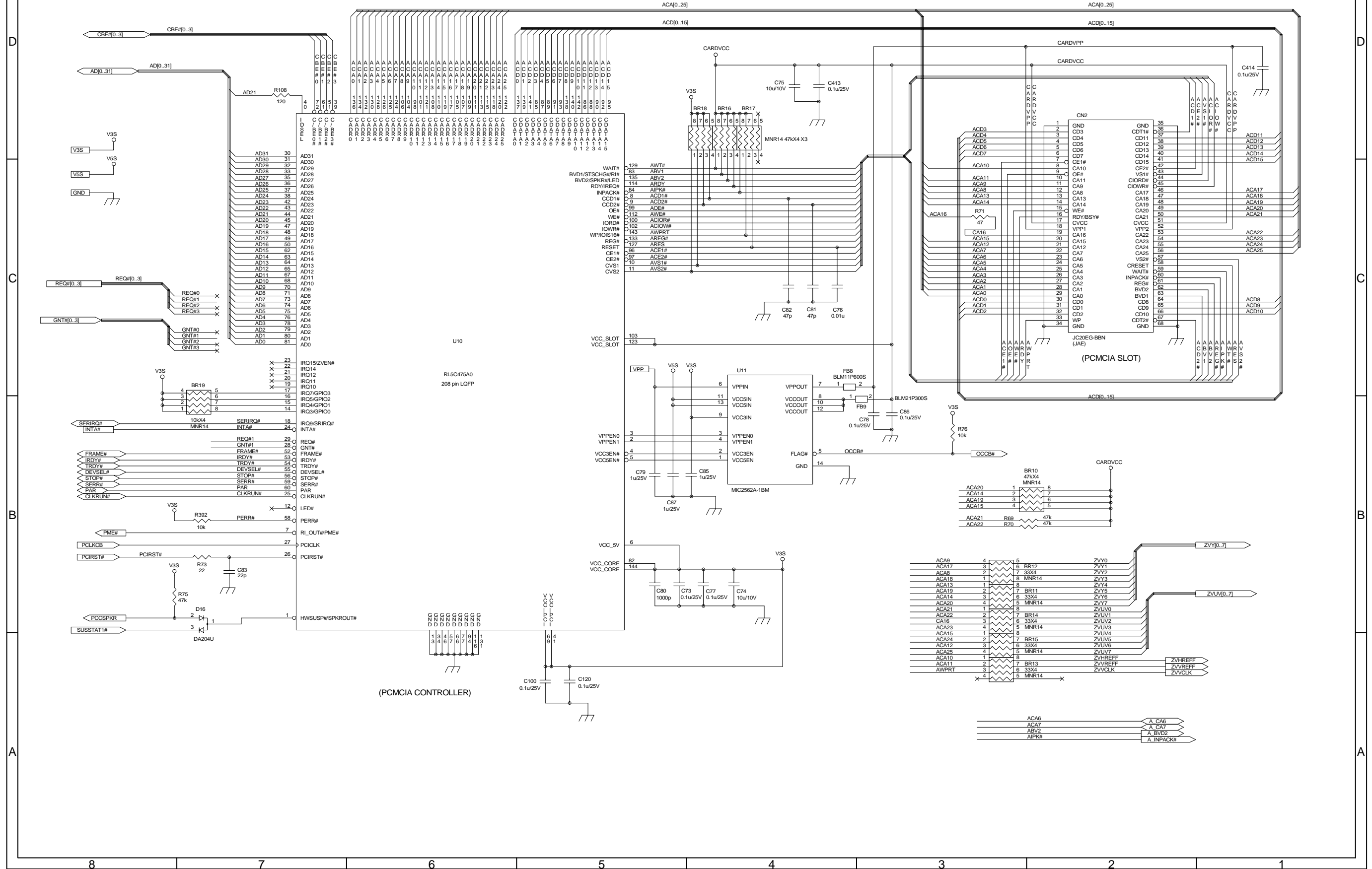

# A100U,Y,C,A VIDEO CONTROLLER (REV 1.E)

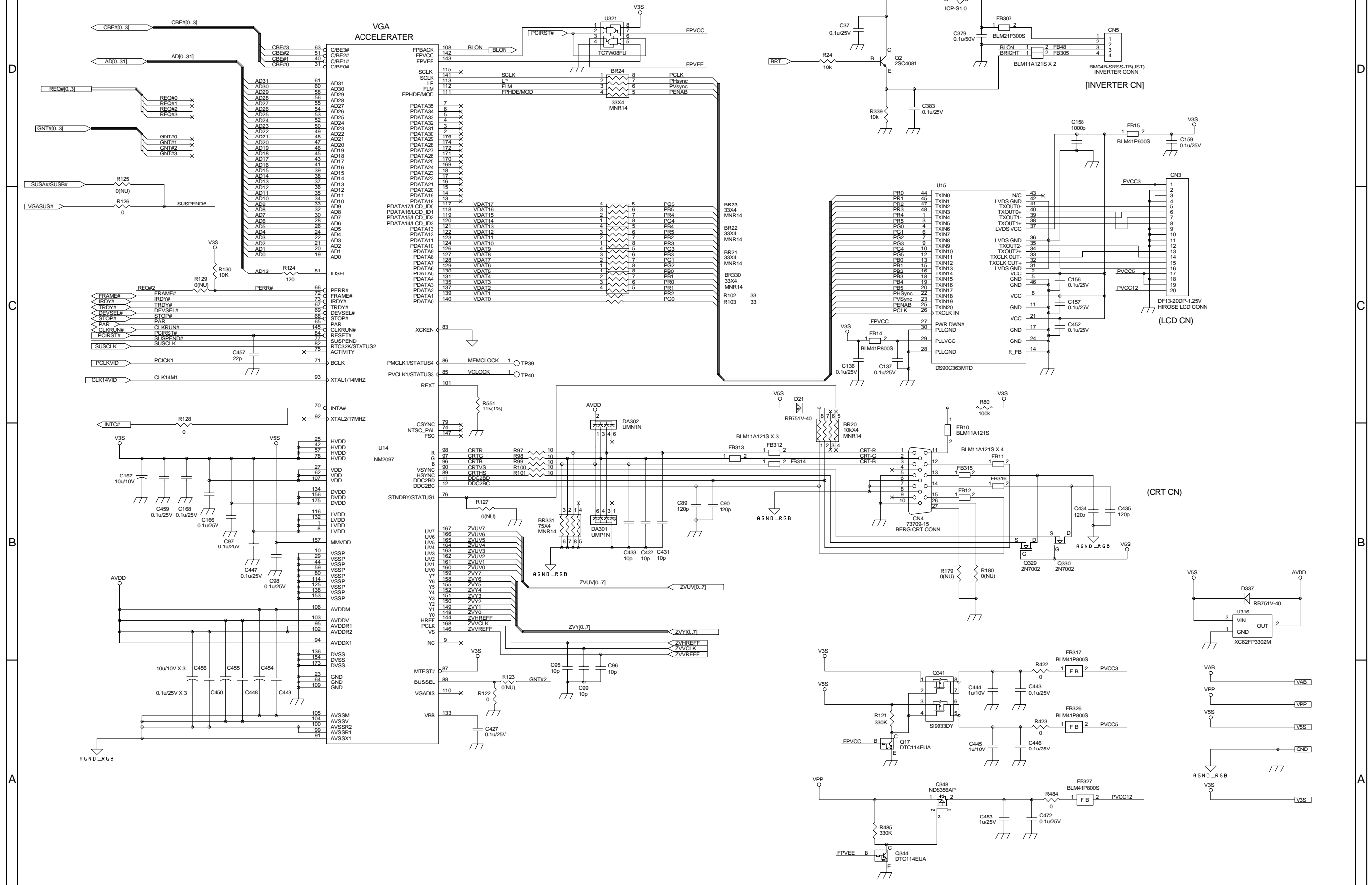

# A100U,Y,C,A IDE/USB INTERFACE (REV 1.E)

## IDE port

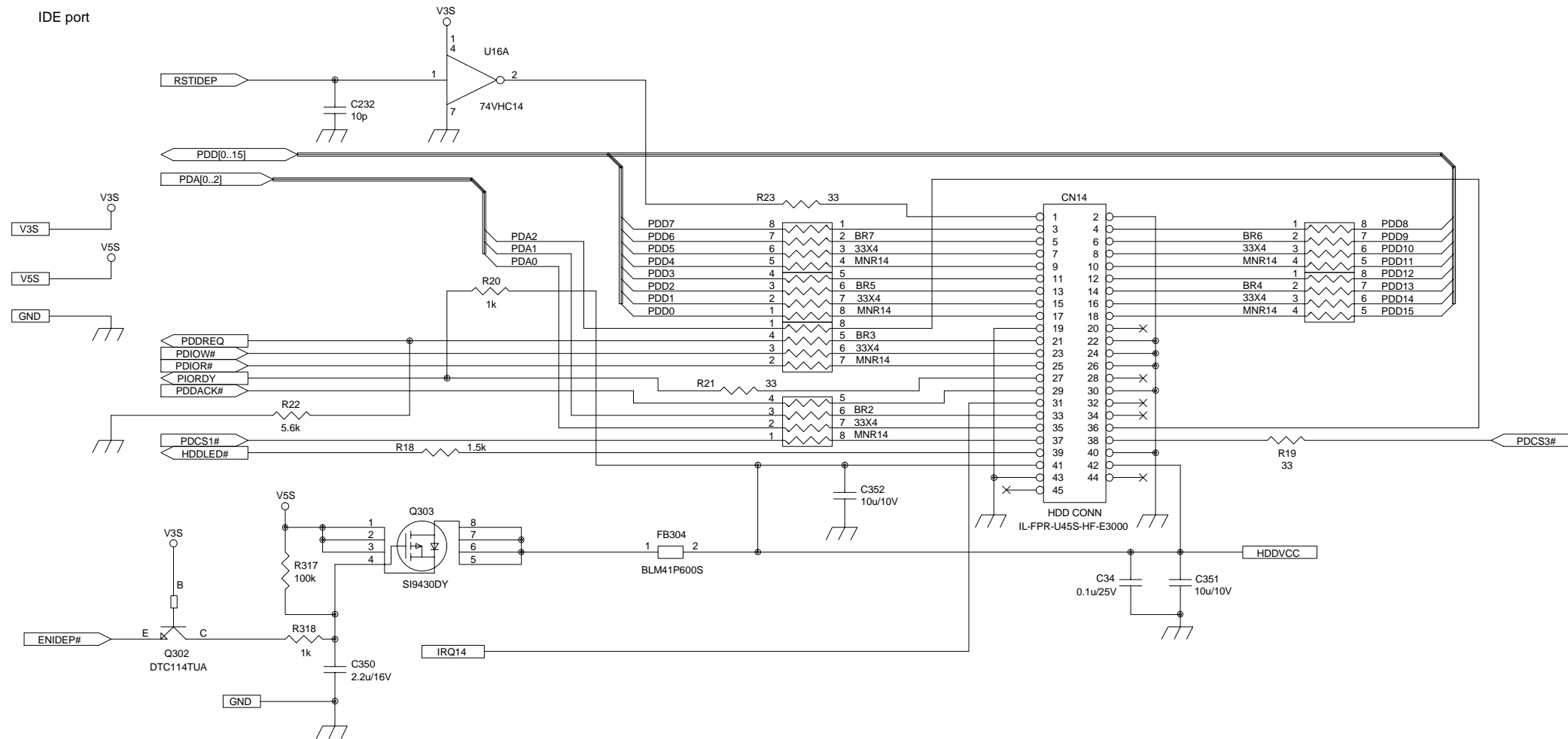

## USB port

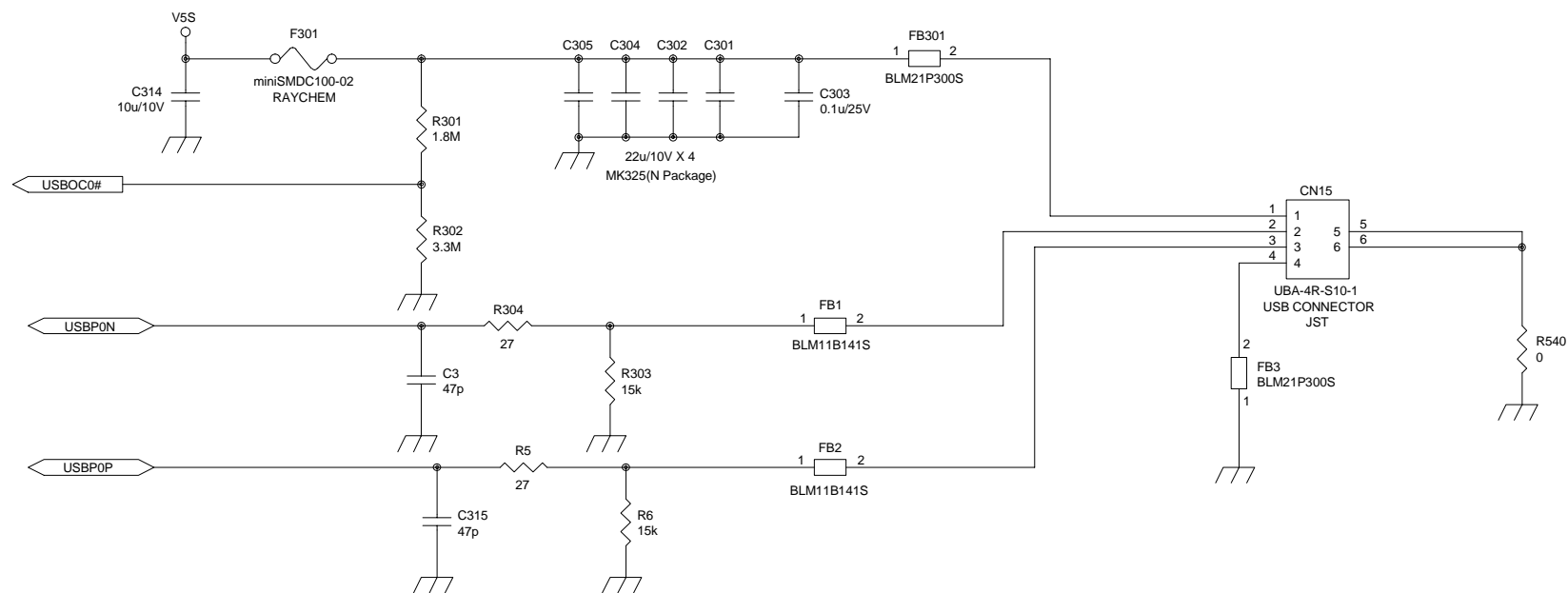

A100U,Y,C,A BIOS AND KEYBOARD CONT. (REV 1.E)

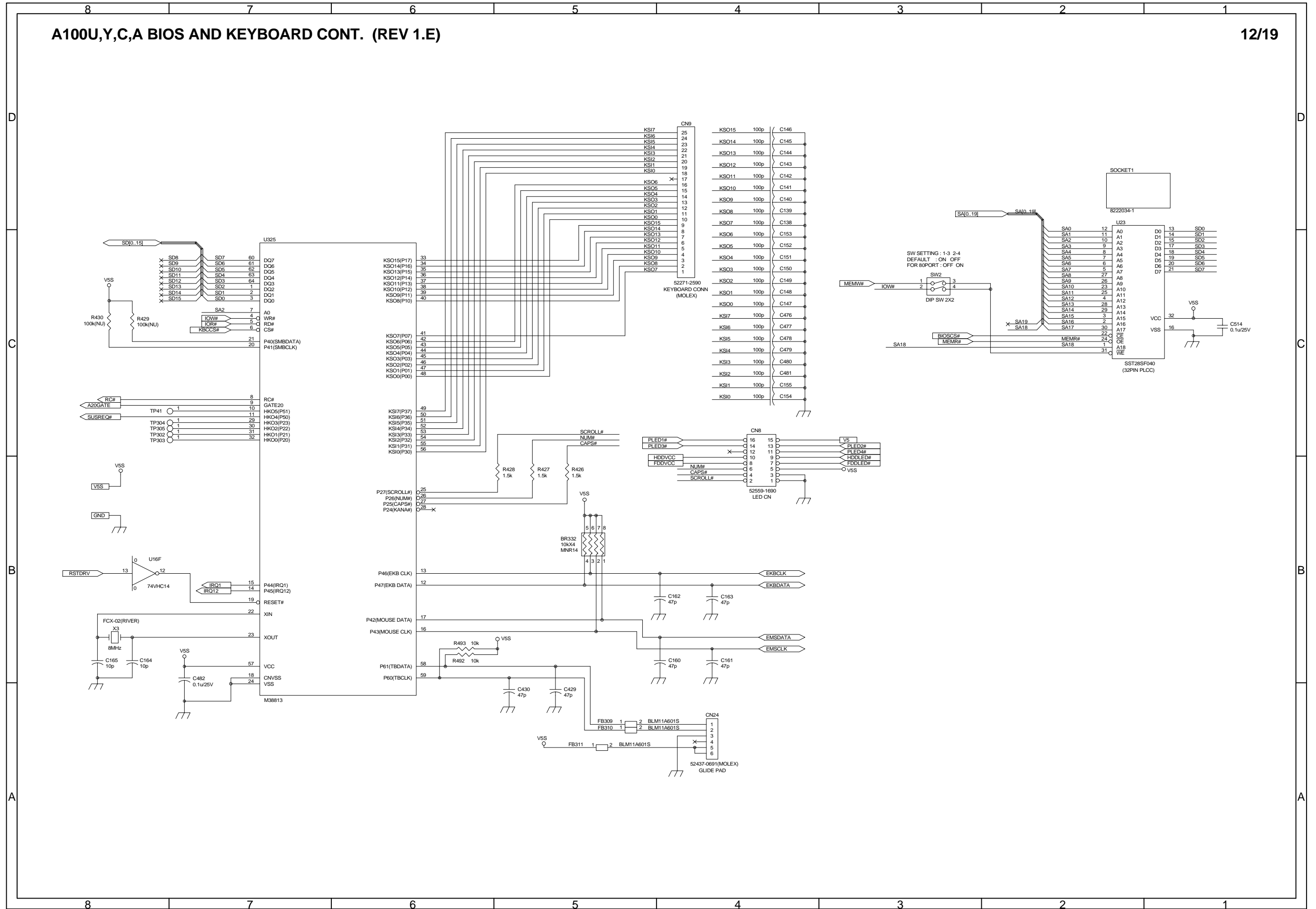



# A100U,Y,C,A AUDIO CONTROLLER (REV 1.E)

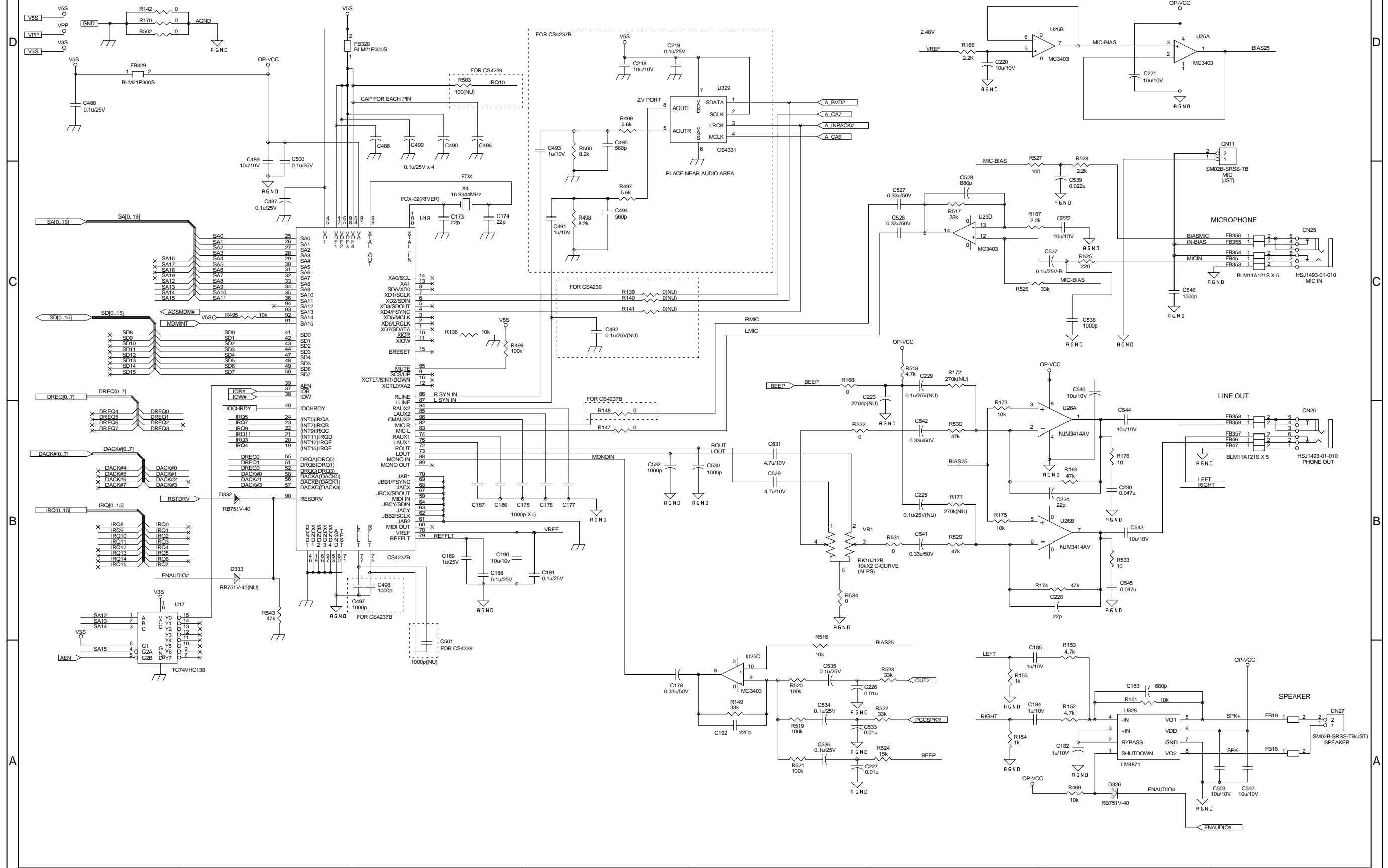

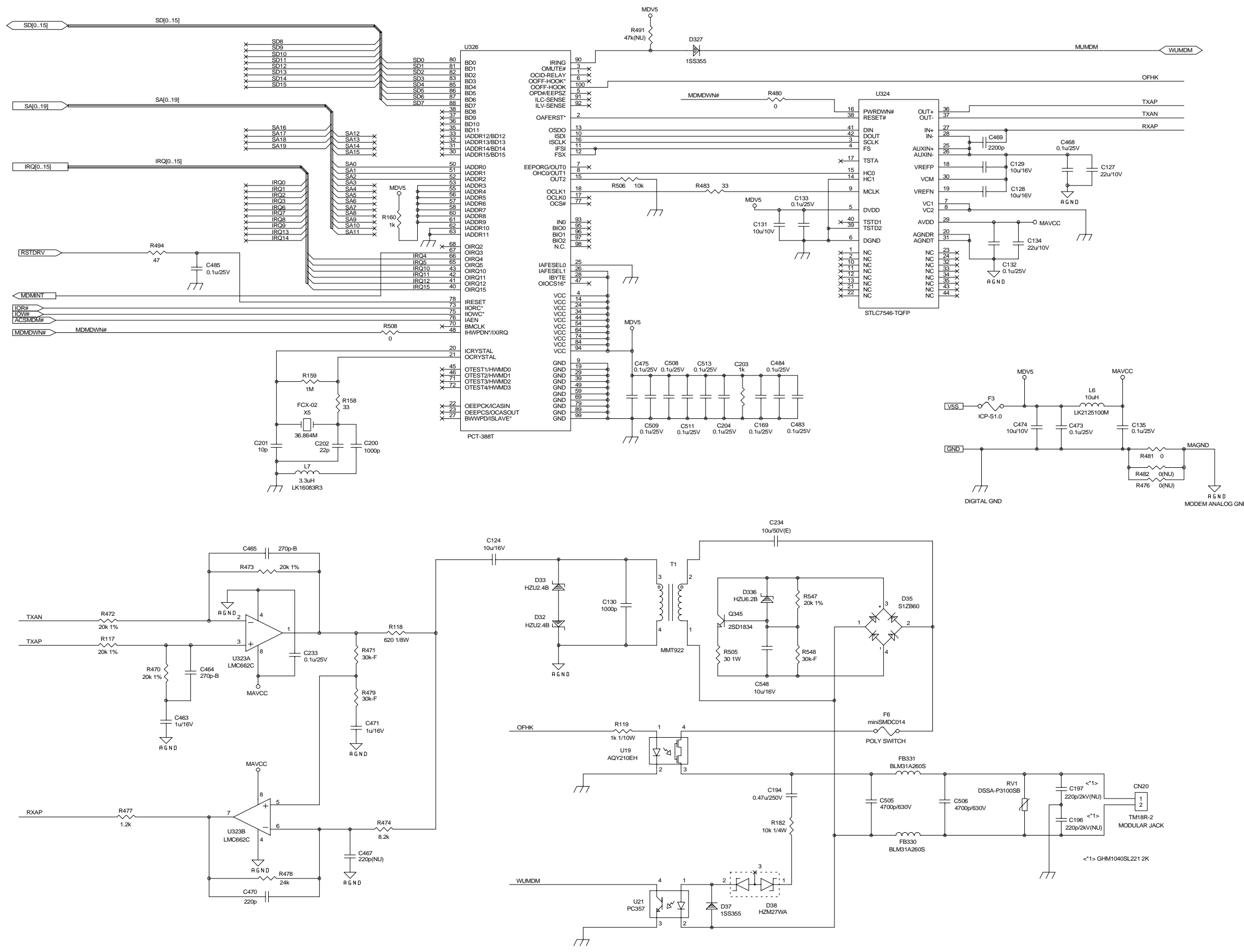

A100U,Y,C,A CHARGER MAIN (REV 1.E)

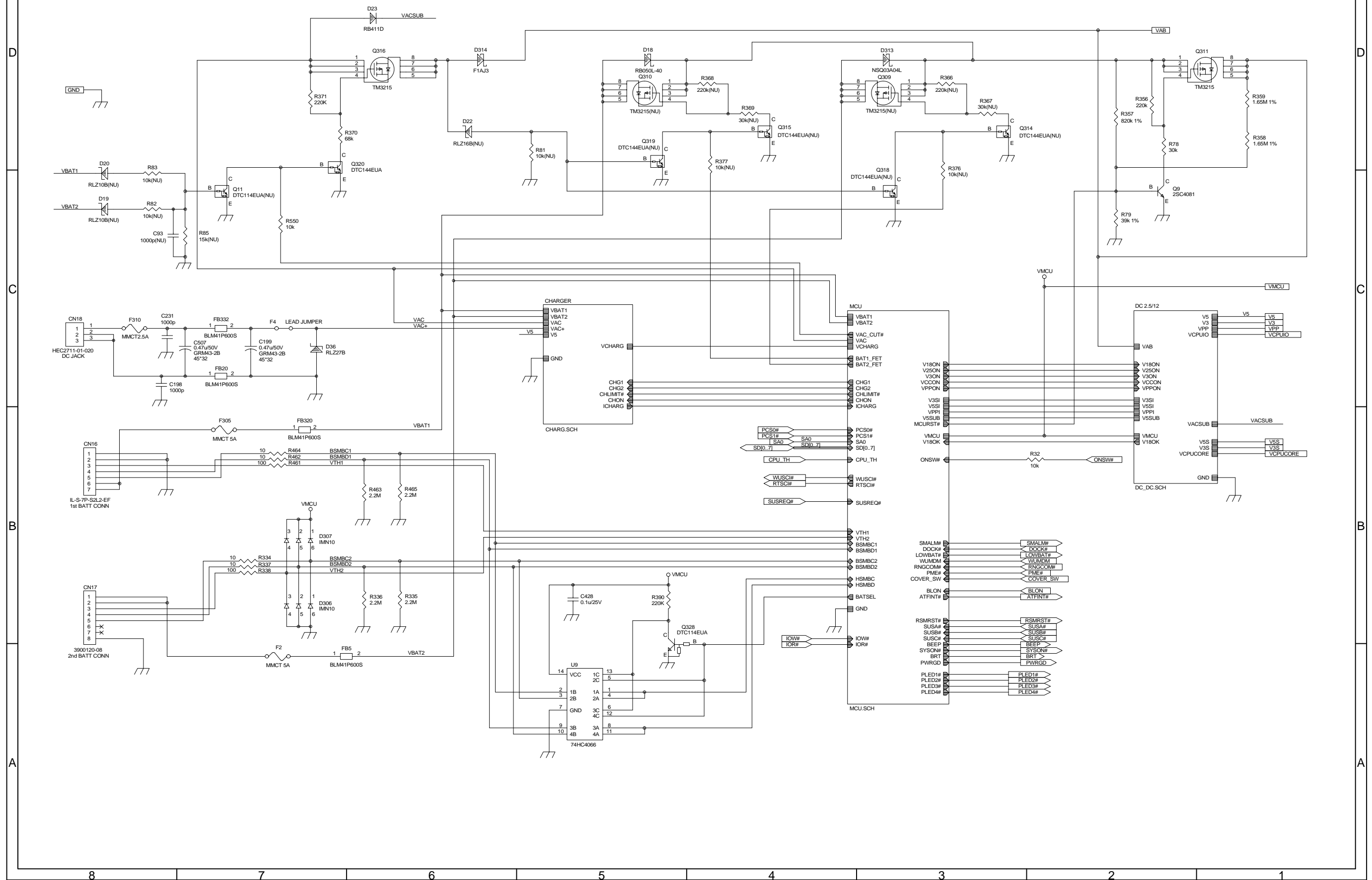



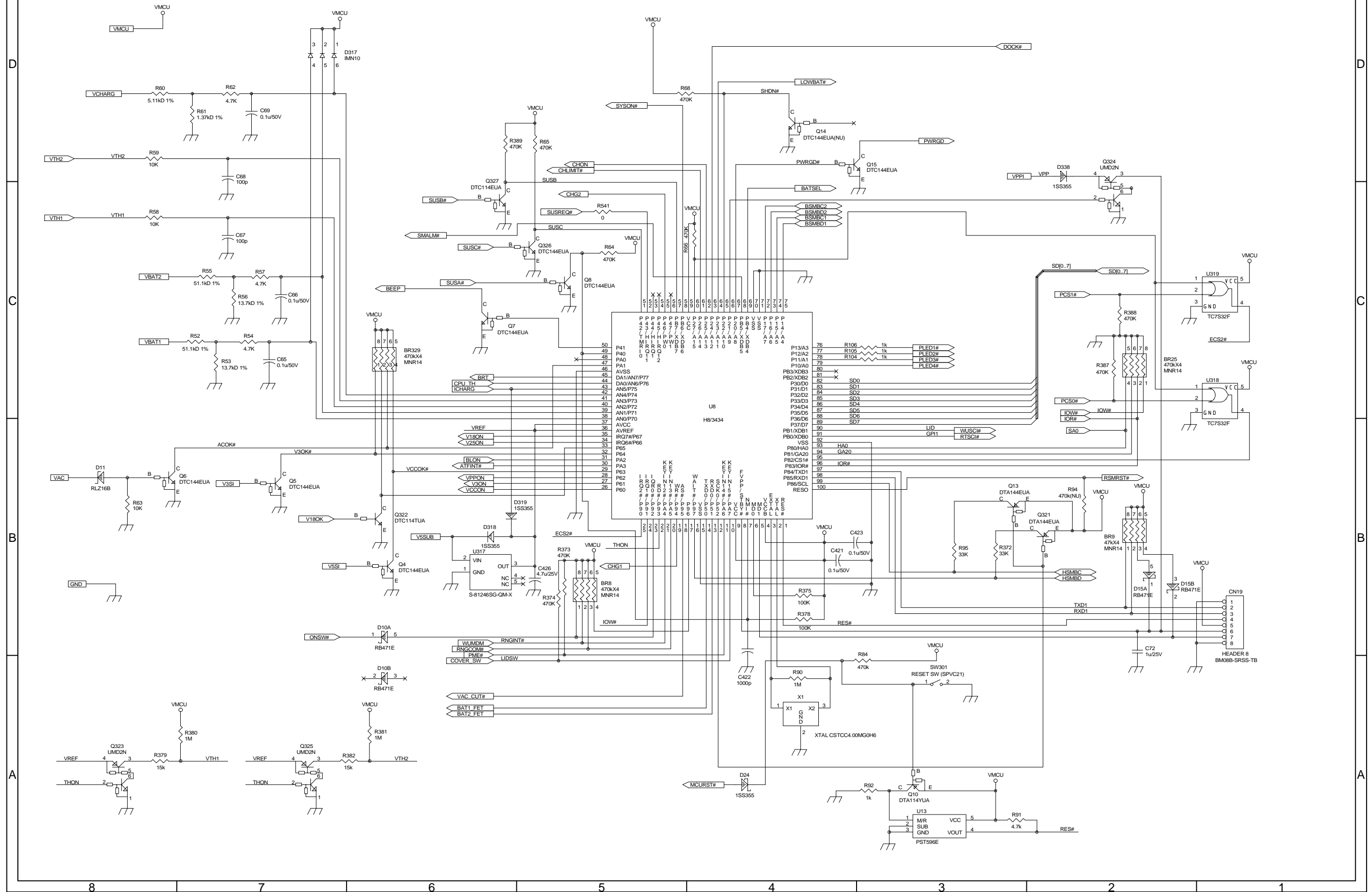

A100U,Y,C,A DC/DC (REV 1.E)

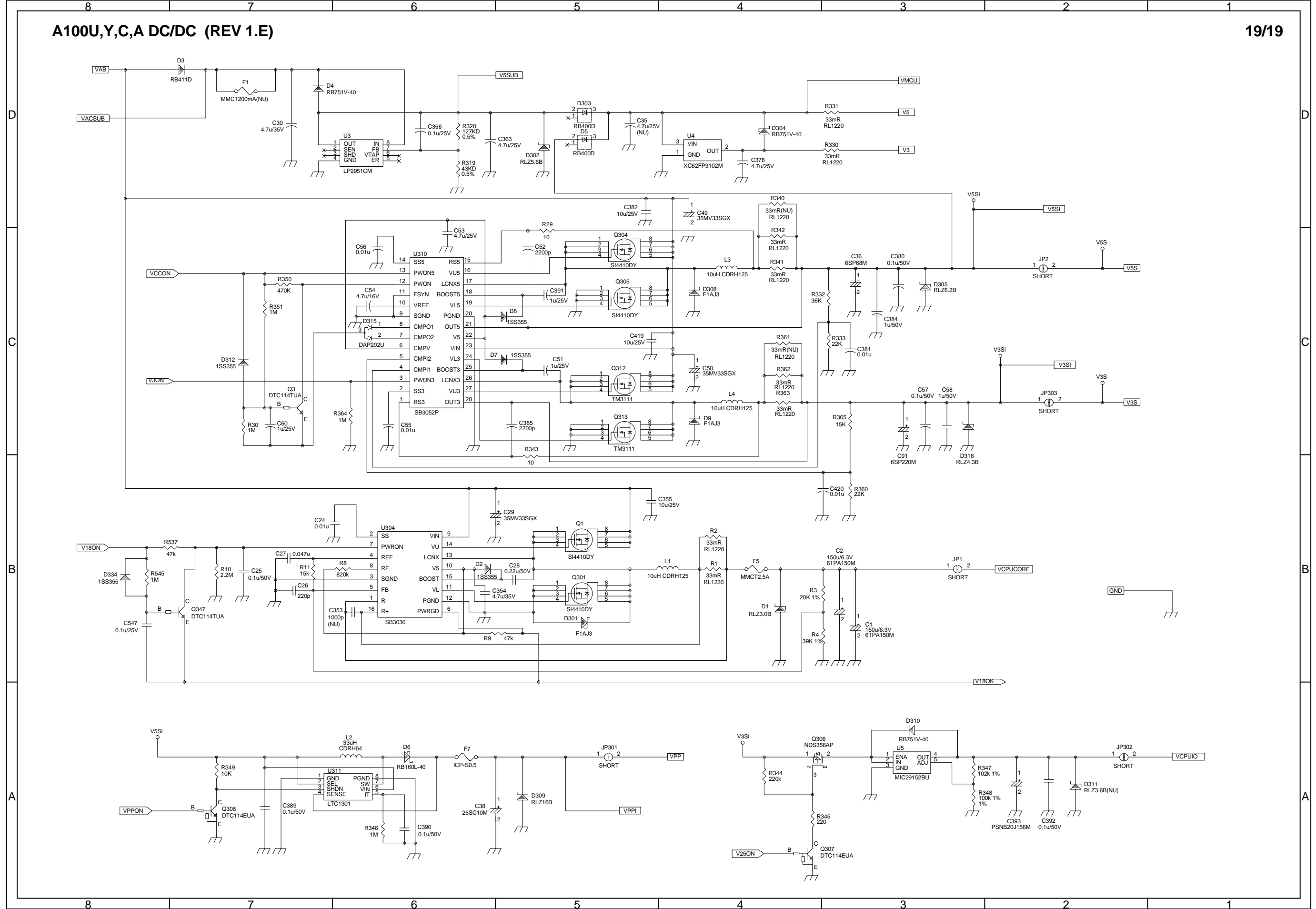

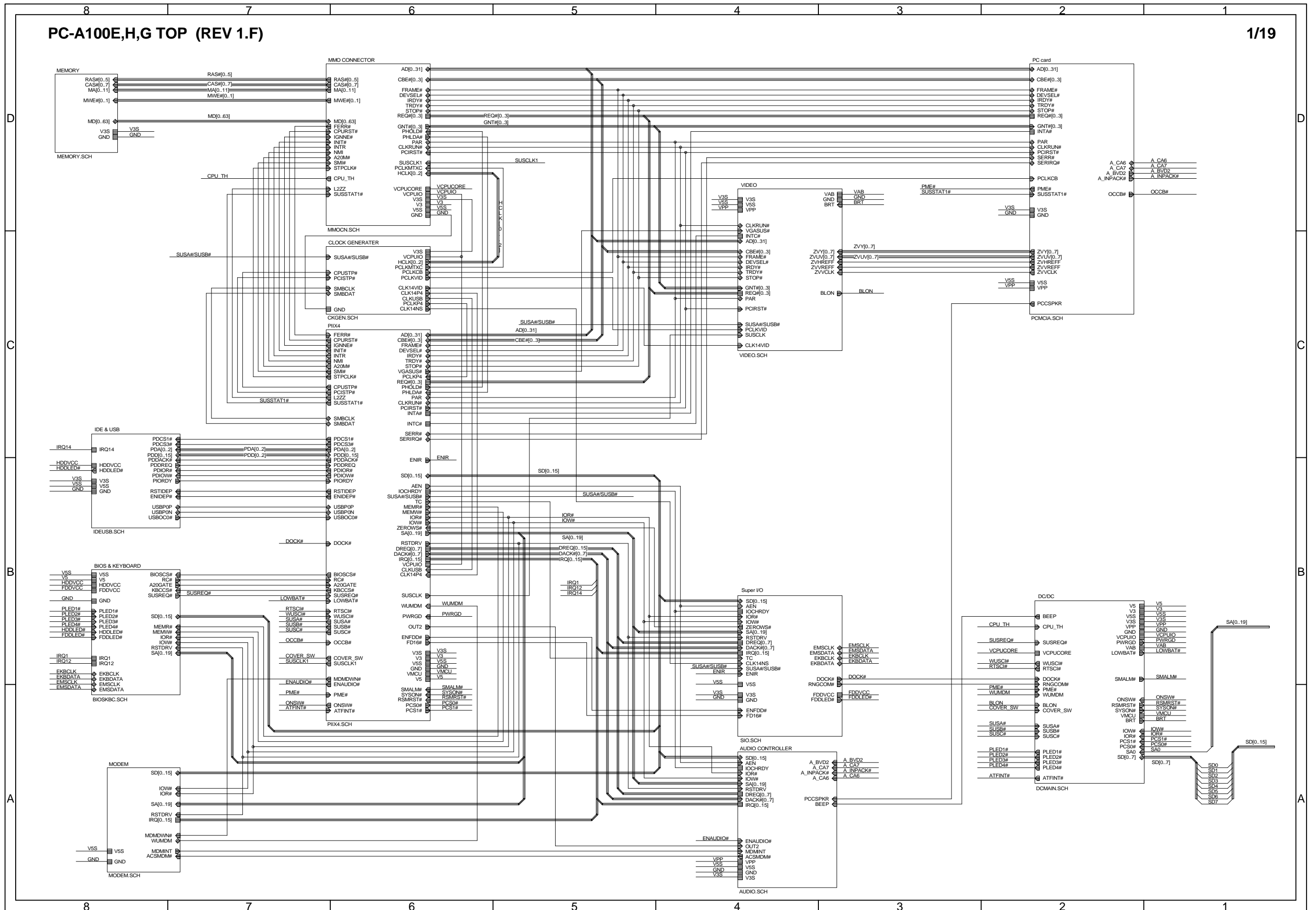

A100E,H,G I/O TO CPU CONNECTOR (REV 1.F)

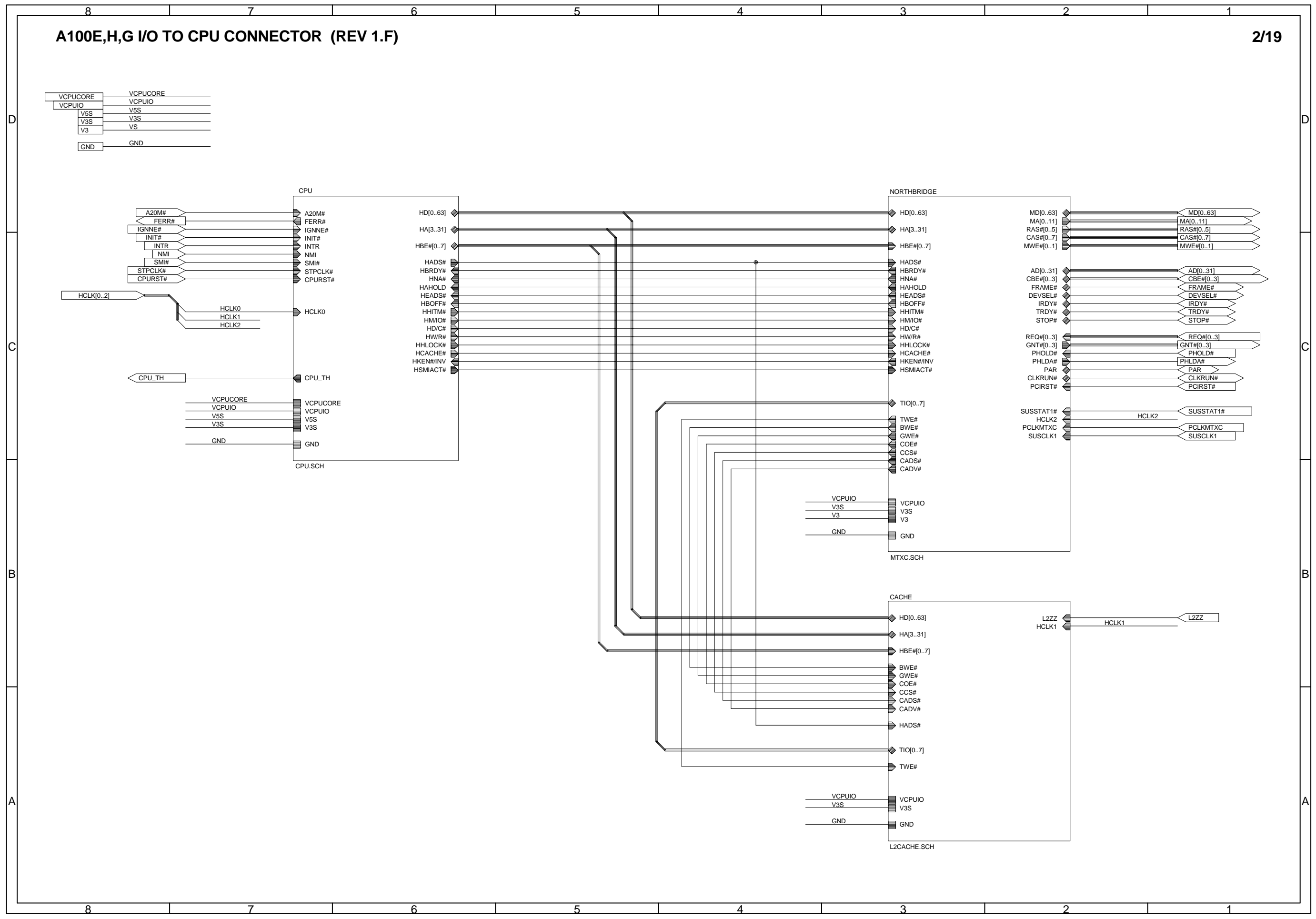

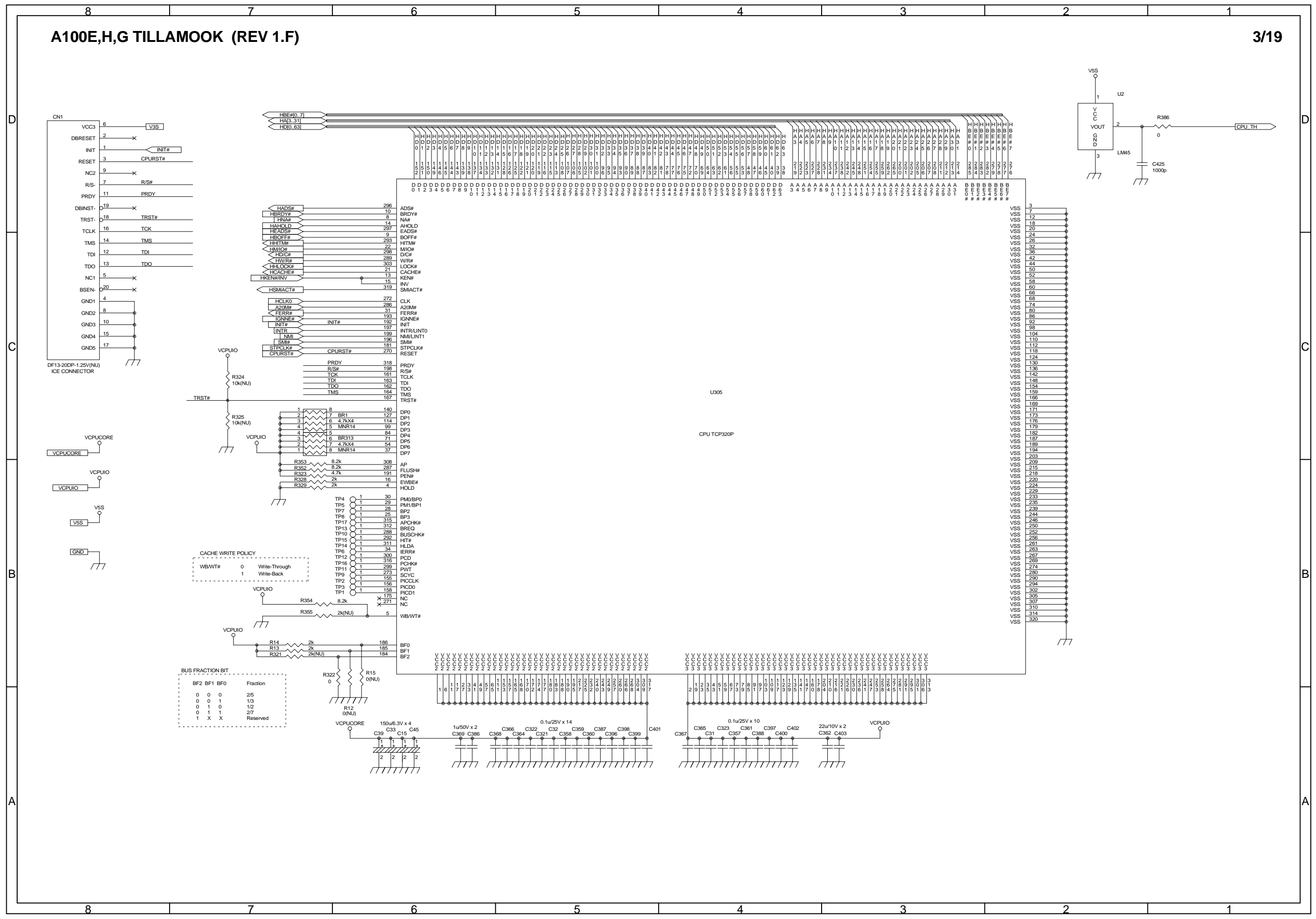

# A100E,H,G Northbridge (REV 1.F)

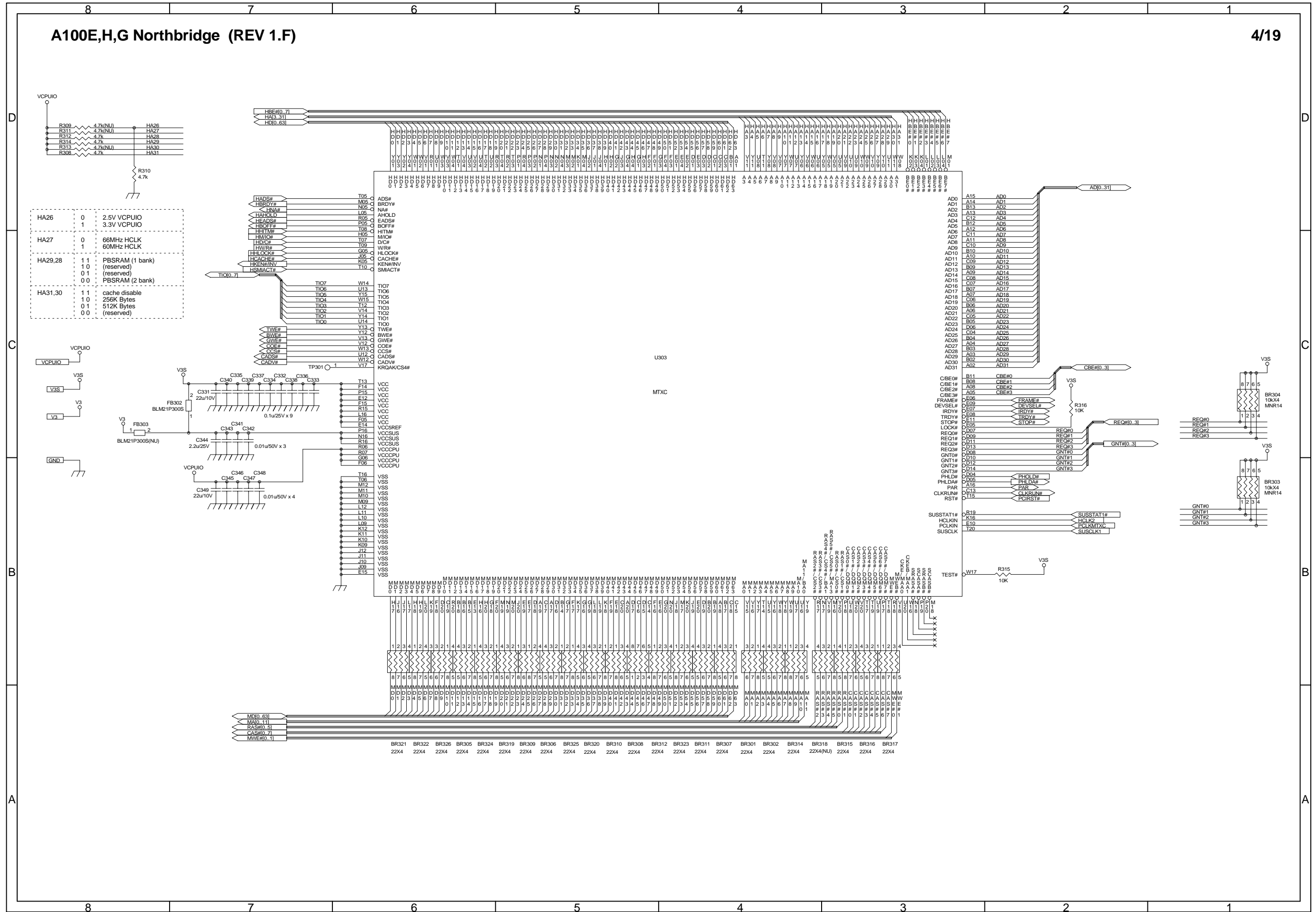

HA26	0	2.5V VCPUIO
	1	3.3V VCPUIO
HA27	0	66MHz HCLK
	1	60MHz HCLK
HA29,28	1 1	PBSRAM (1 bank)
	1 0	(reserved)
	0 1	(reserved)
	0 0	PBSRAM (2 bank)
HA31,30	1 1	cache disable
	1 0	256K Bytes
	0 1	512K Bytes
	0 0	(reserved)

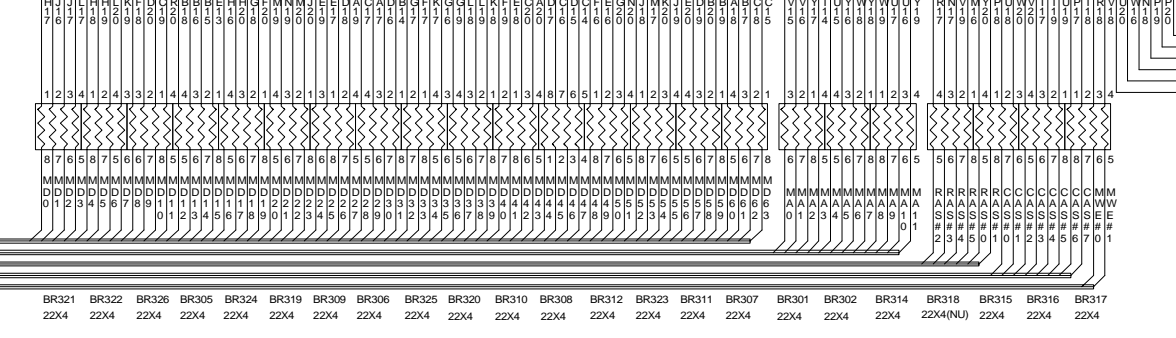
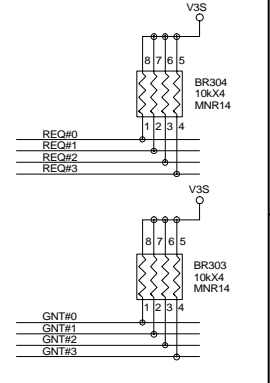
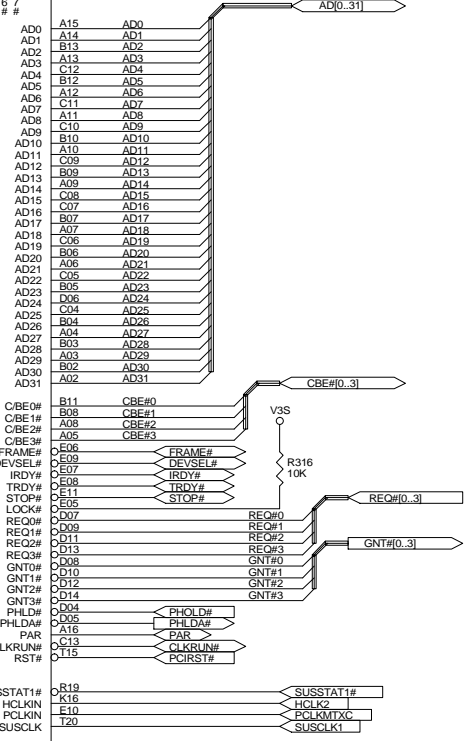
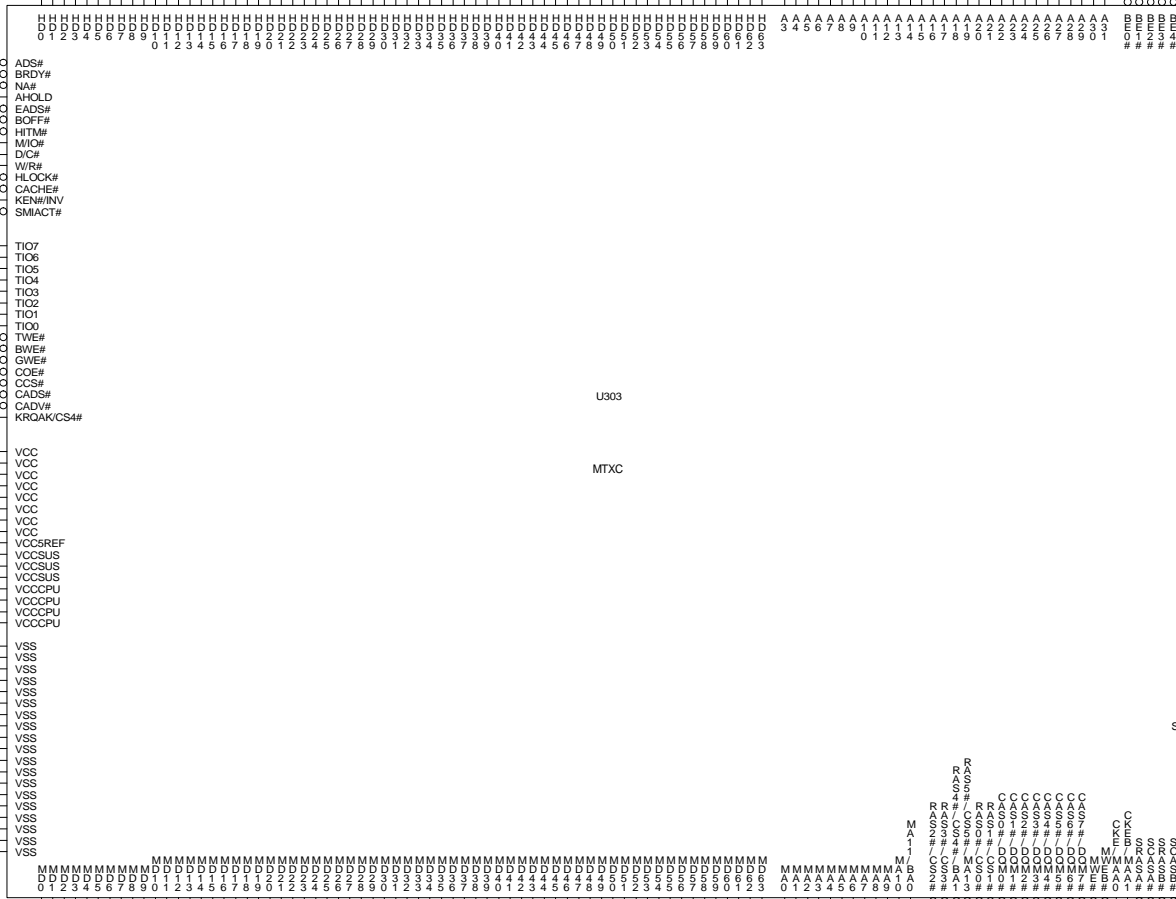
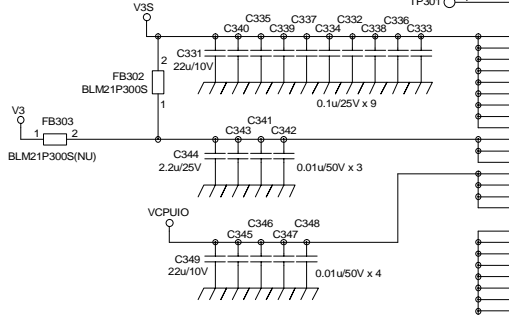
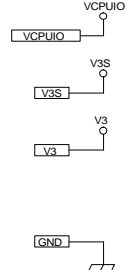

# A100E,H,G CACHE AND TAG SRAM (REV 1.F)

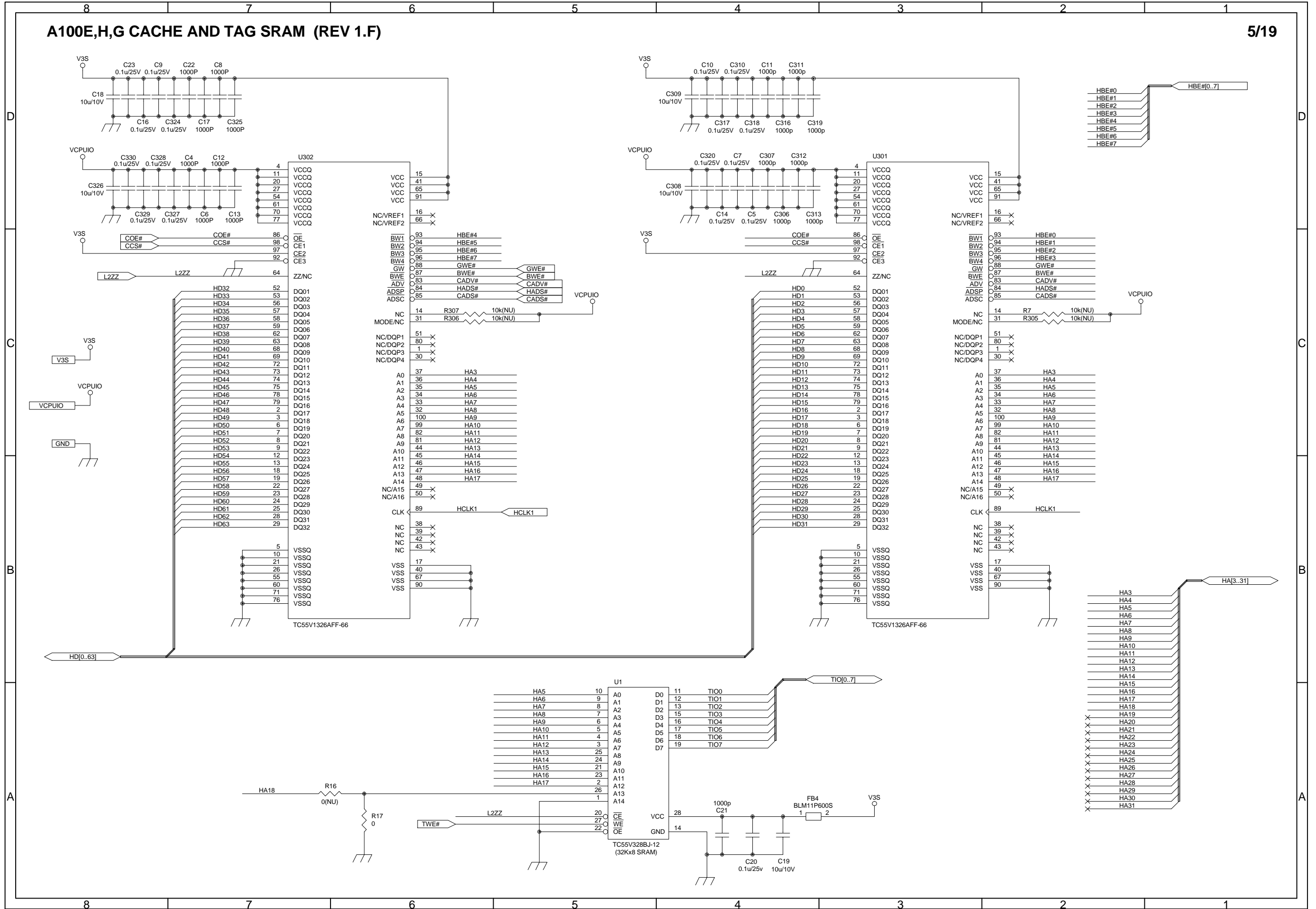

A100E,H,G MAIN MEMORY EDO 64MB (REV 1.F)

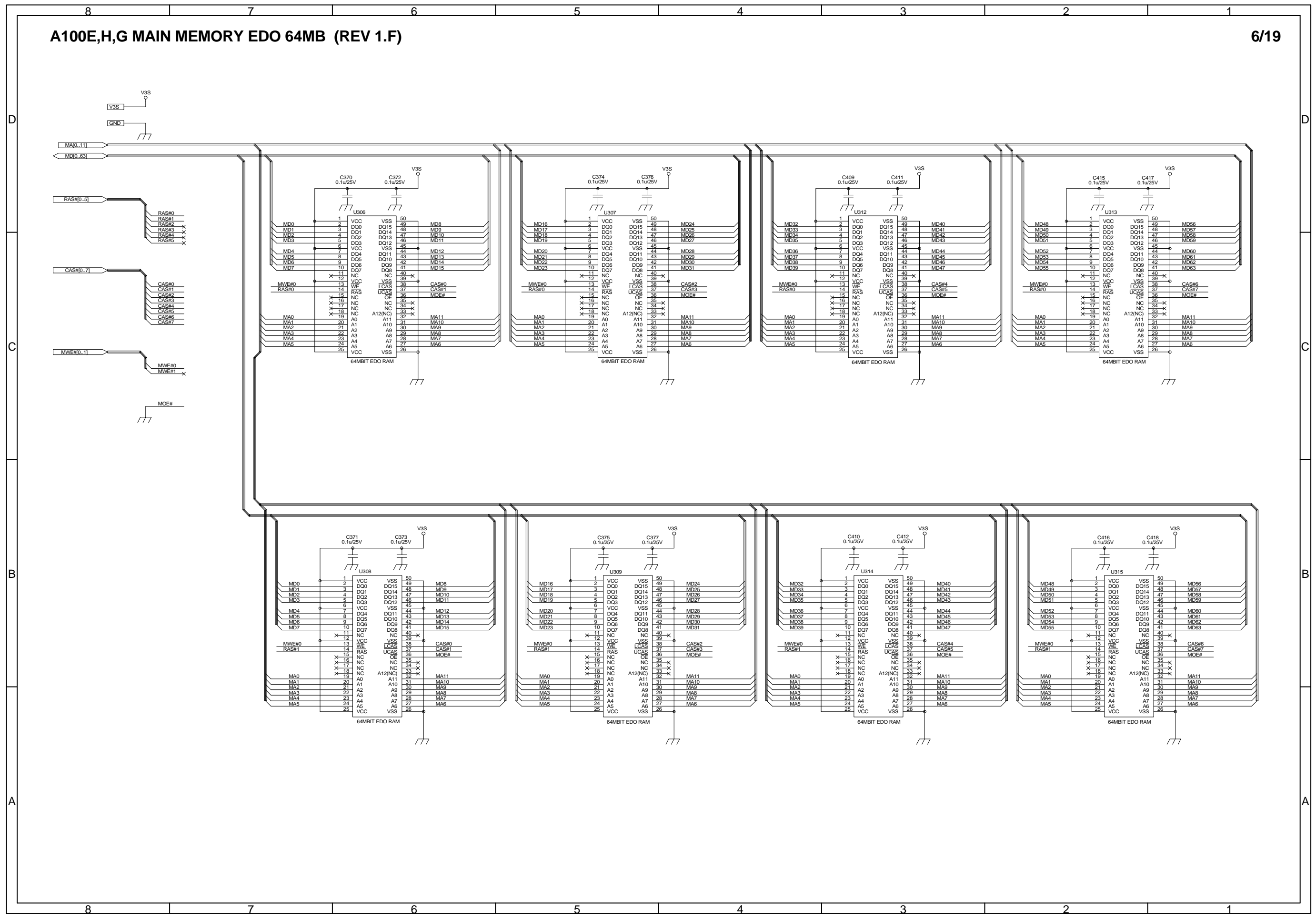



# A100E,H,G CLOCK GENERATOR AND DRIVER (REV 1.F)

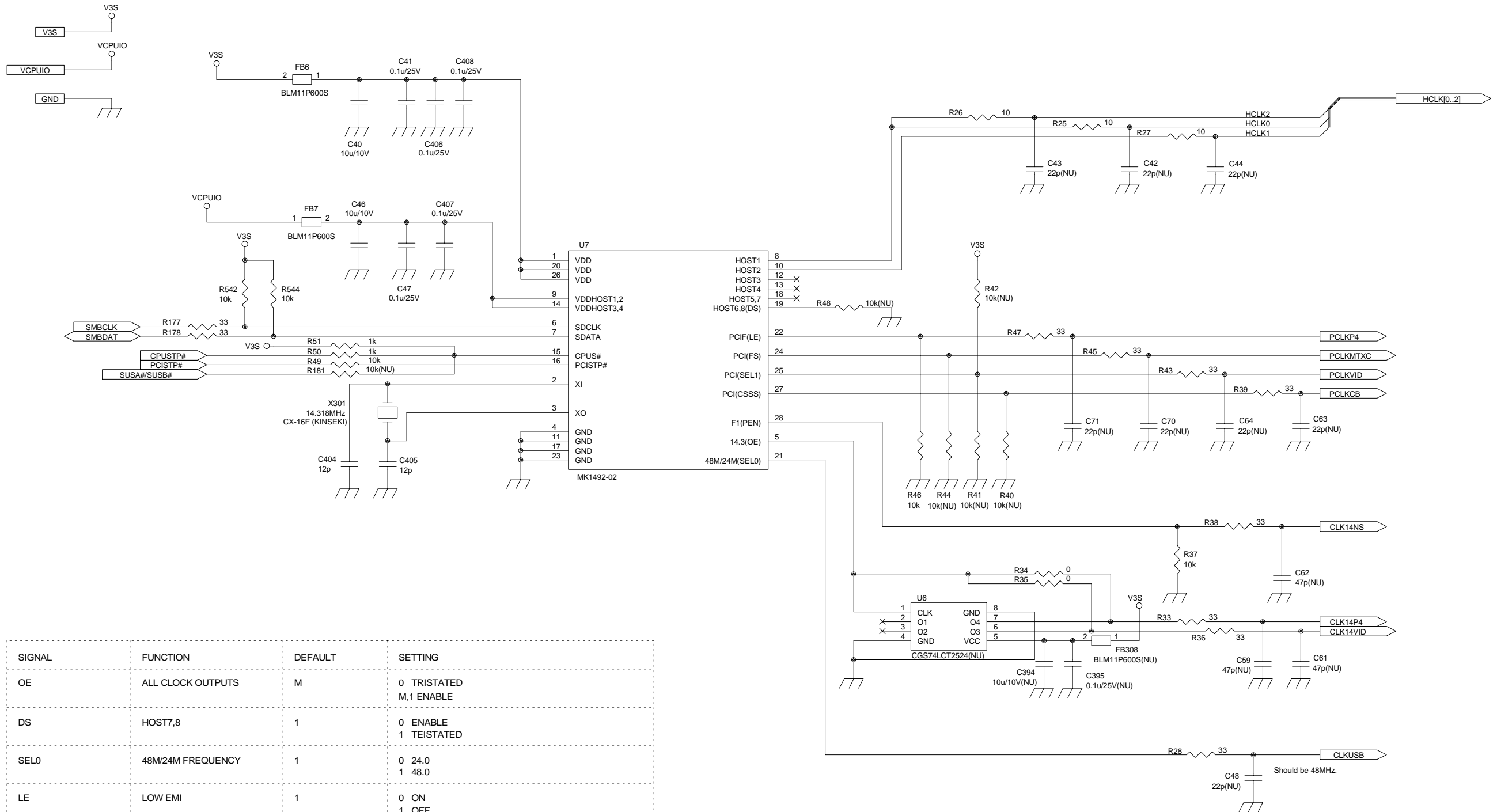

SIGNAL	FUNCTION	DEFAULT	SETTING
OE	ALL CLOCK OUTPUTS	M	0 TRISTATED M,1 ENABLE
DS	HOST7,8	1	0 ENABLE 1 TEISTATED
SEL0	48M/24M FREQUENCY	1	0 24.0 1 48.0
LE	LOW EMI	1	0 ON 1 OFF
CPUS#/CSSS/FS	HOST/PCI FREQUENCY	1/1/1	1/X/0 60.0(OE=M) 50.0(OE=1) 1/X/1 66.6(OE=M) 75.0(OE=1) M/0/X 33.33(OE=M) 33.33(OE=1)
SEL1	F1 FREQUENCY	M	0 PCI M 14.318 1 24.0
PEN	PCIF ENABLE	M	0 Pin25=PCI Pin24=PCI M Pin25=PCI Pin24=PCIF 1 Pin25=PCIF Pin24=PCIF





# A100E,H,G IDE/USB INTERFACE (REV 1.F)

## IDE port

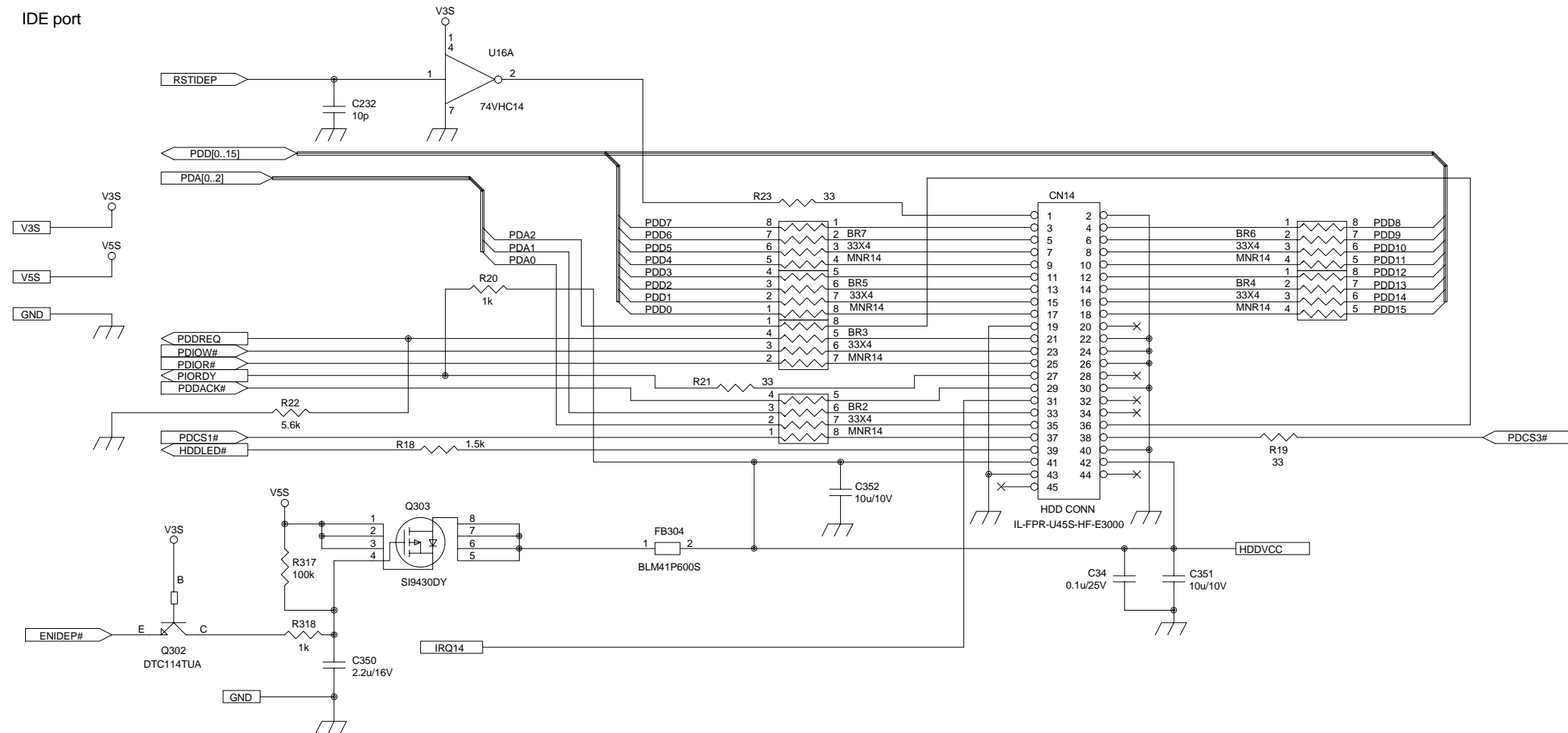

## USB port

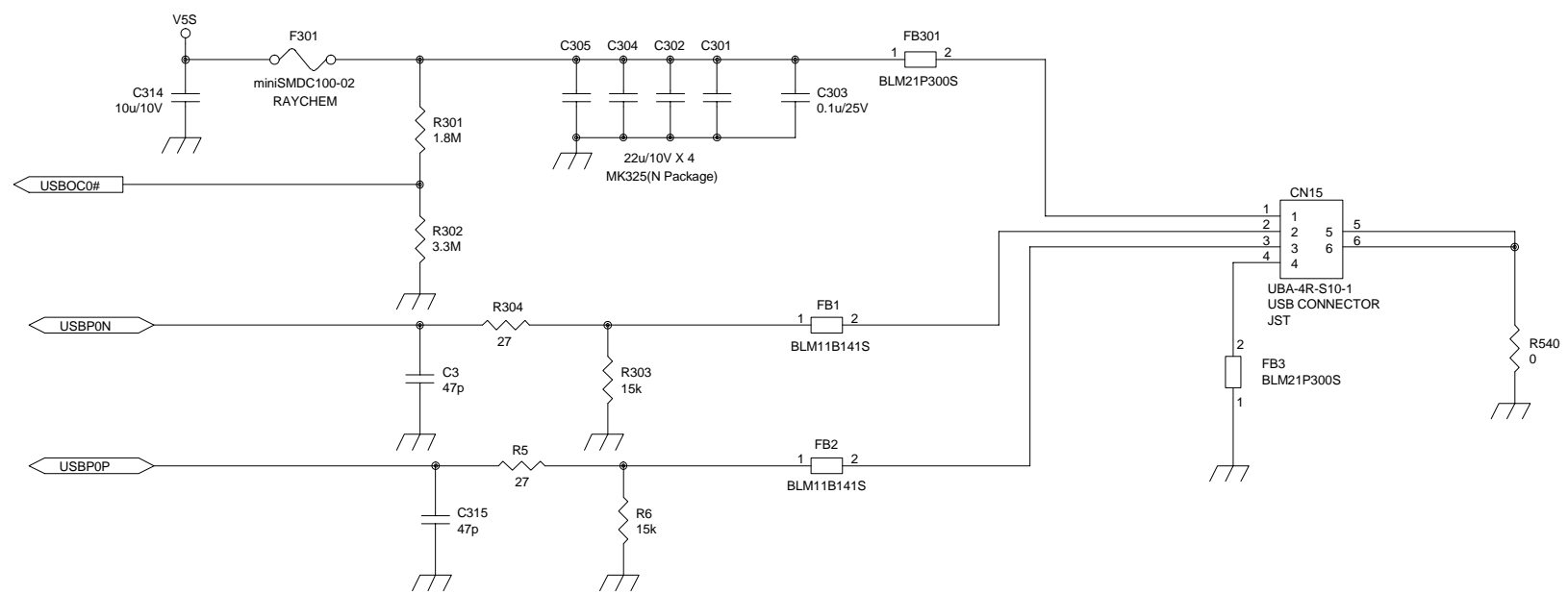

A100E,H,G BIOS AND KEYBOARD CONT. (REV 1.F)

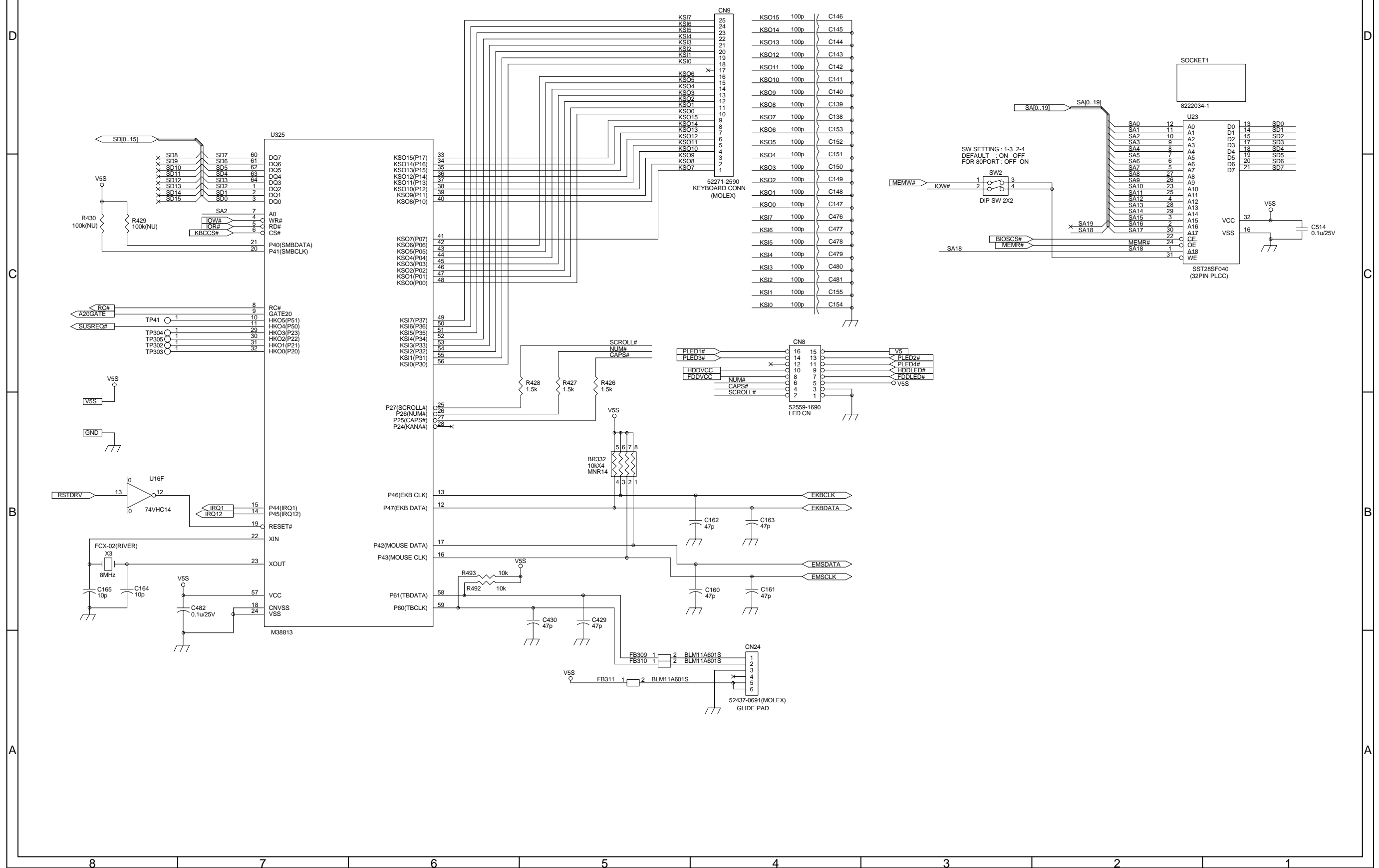





A100E,H,G 56K/SOFT MODEM (REV 1.F)

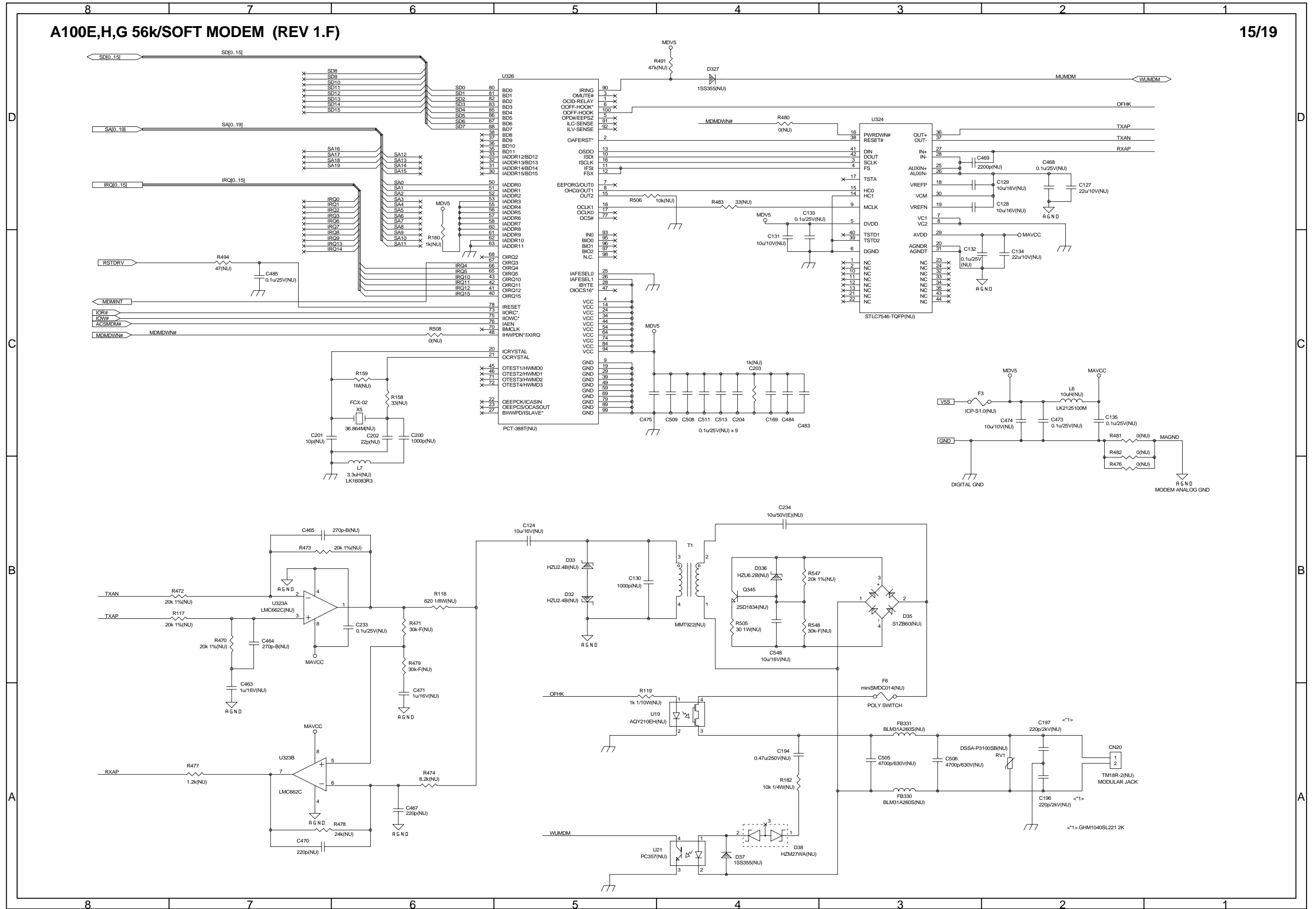

A100E,H,G CHARGER MAIN (REV 1.F)

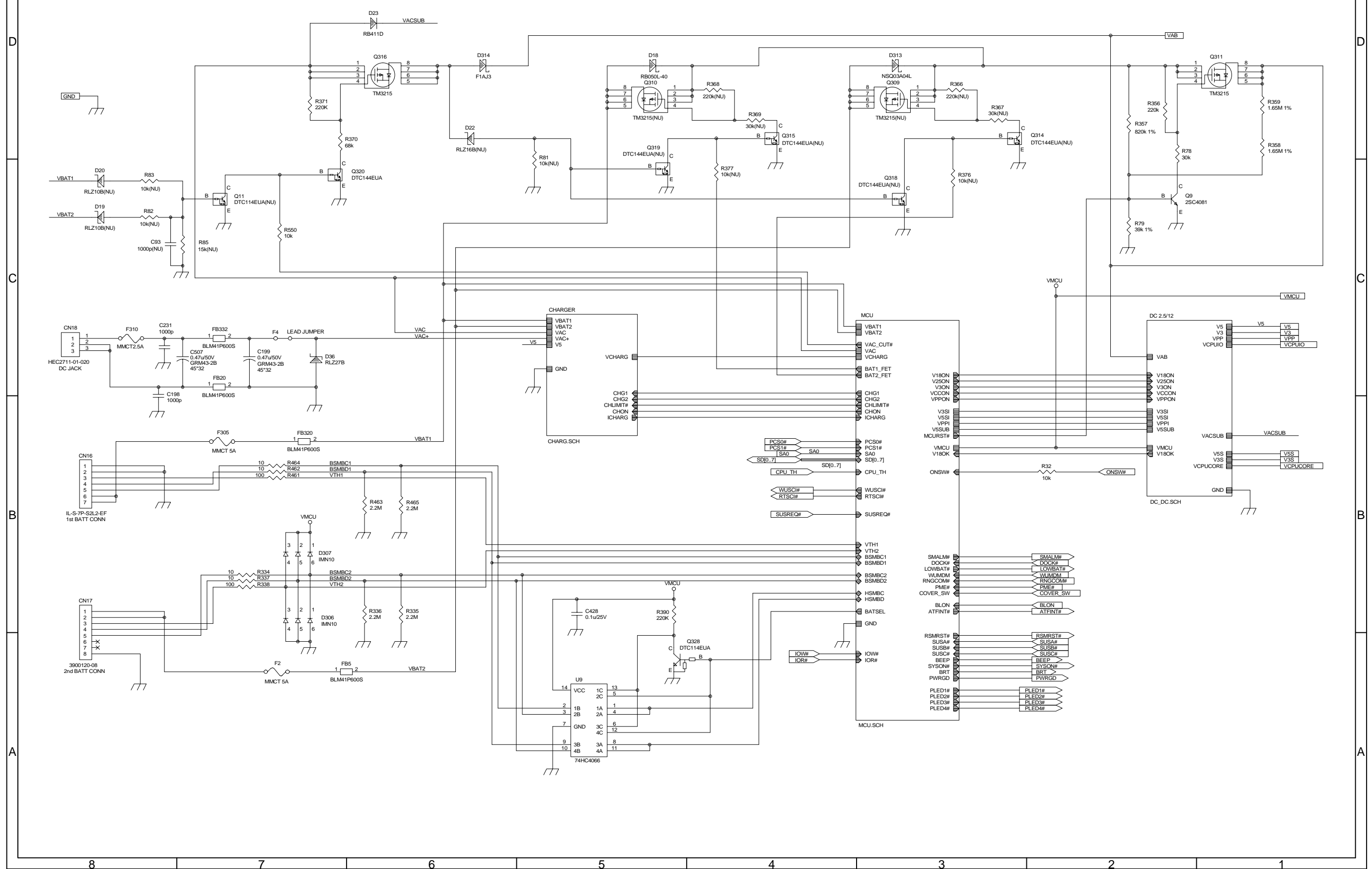





A100E,H,G DC/DC (REV 1.F)

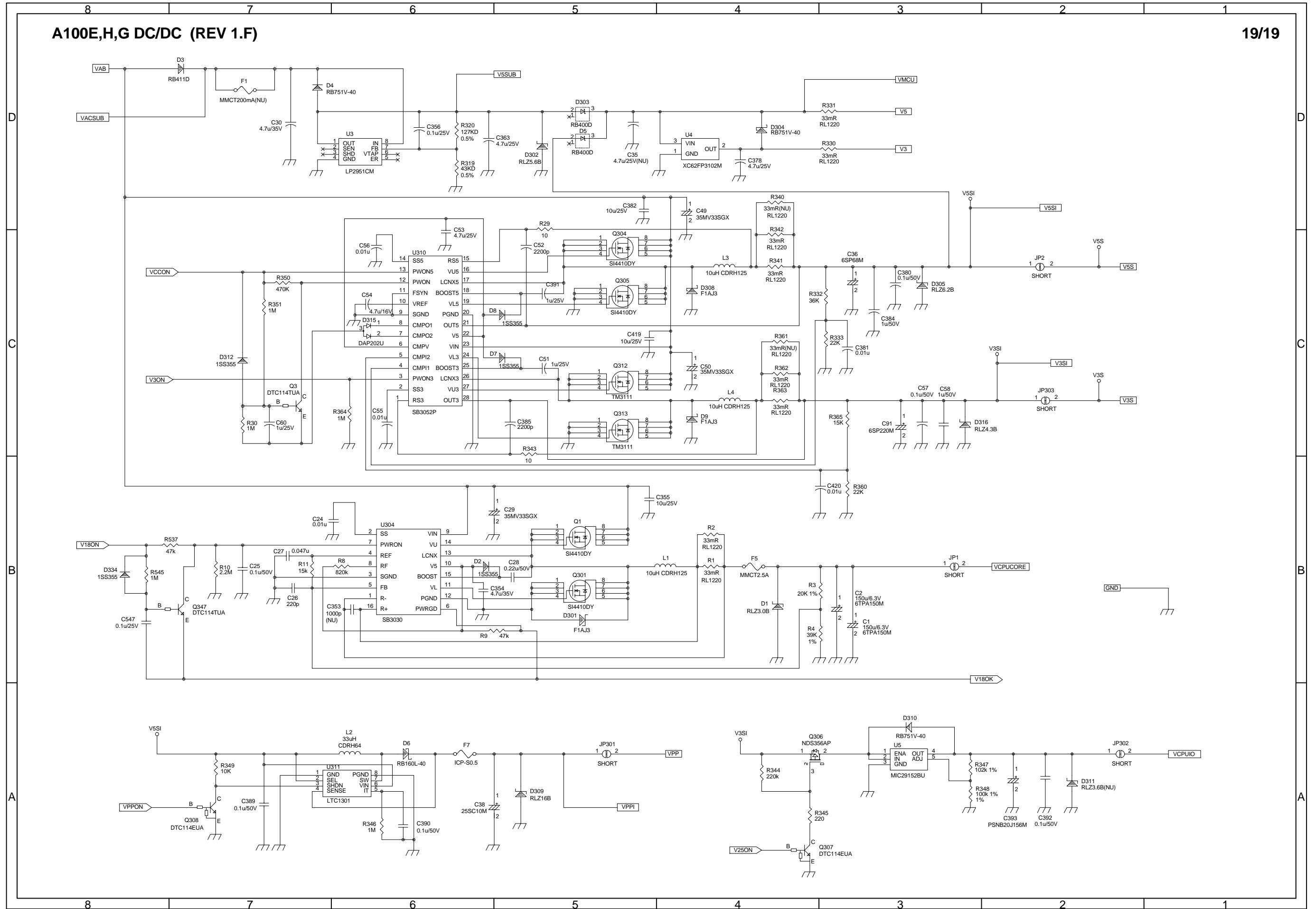

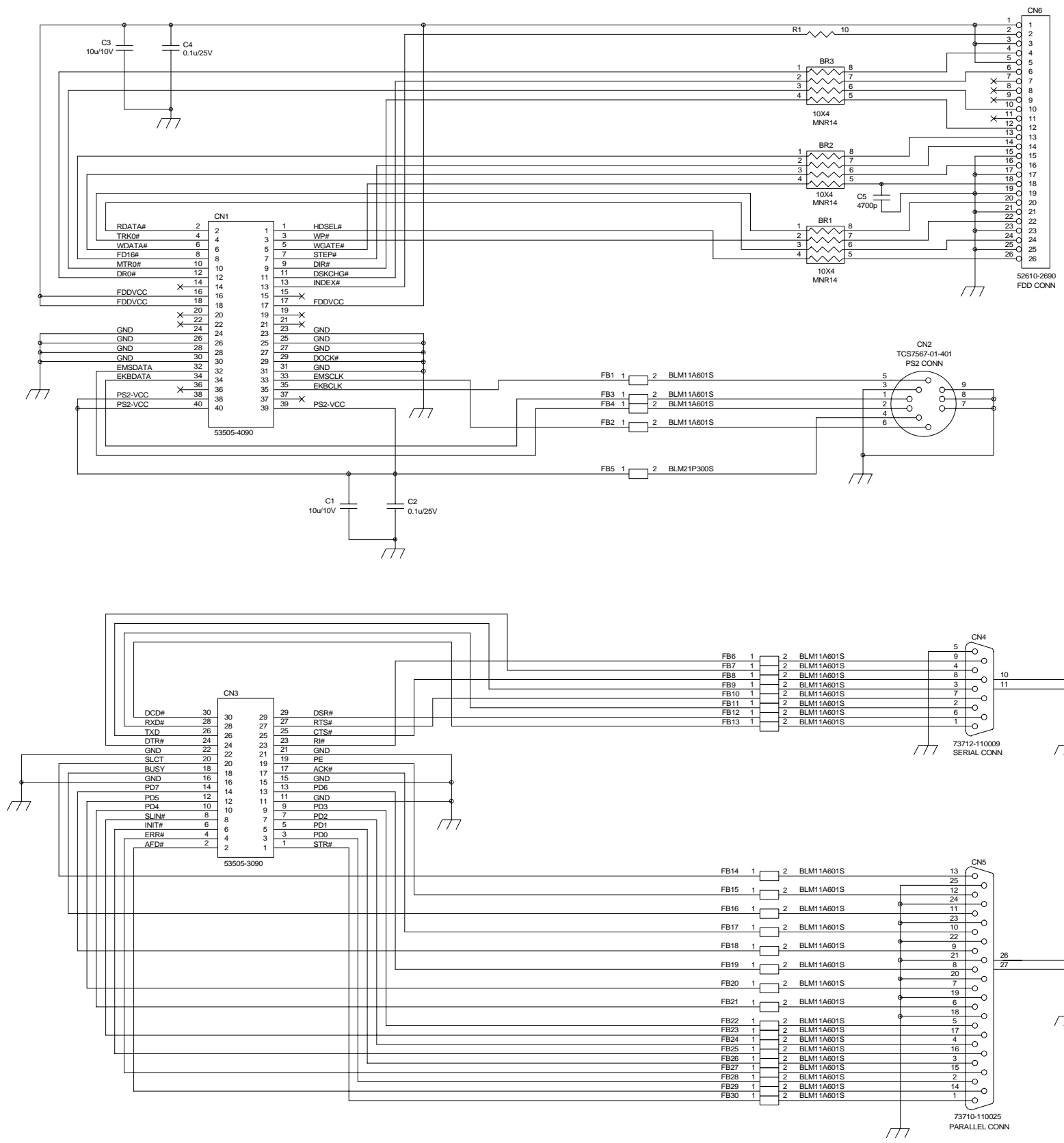

PJ-1 IR & PS/2 PCB (REV 1.0)

1/1

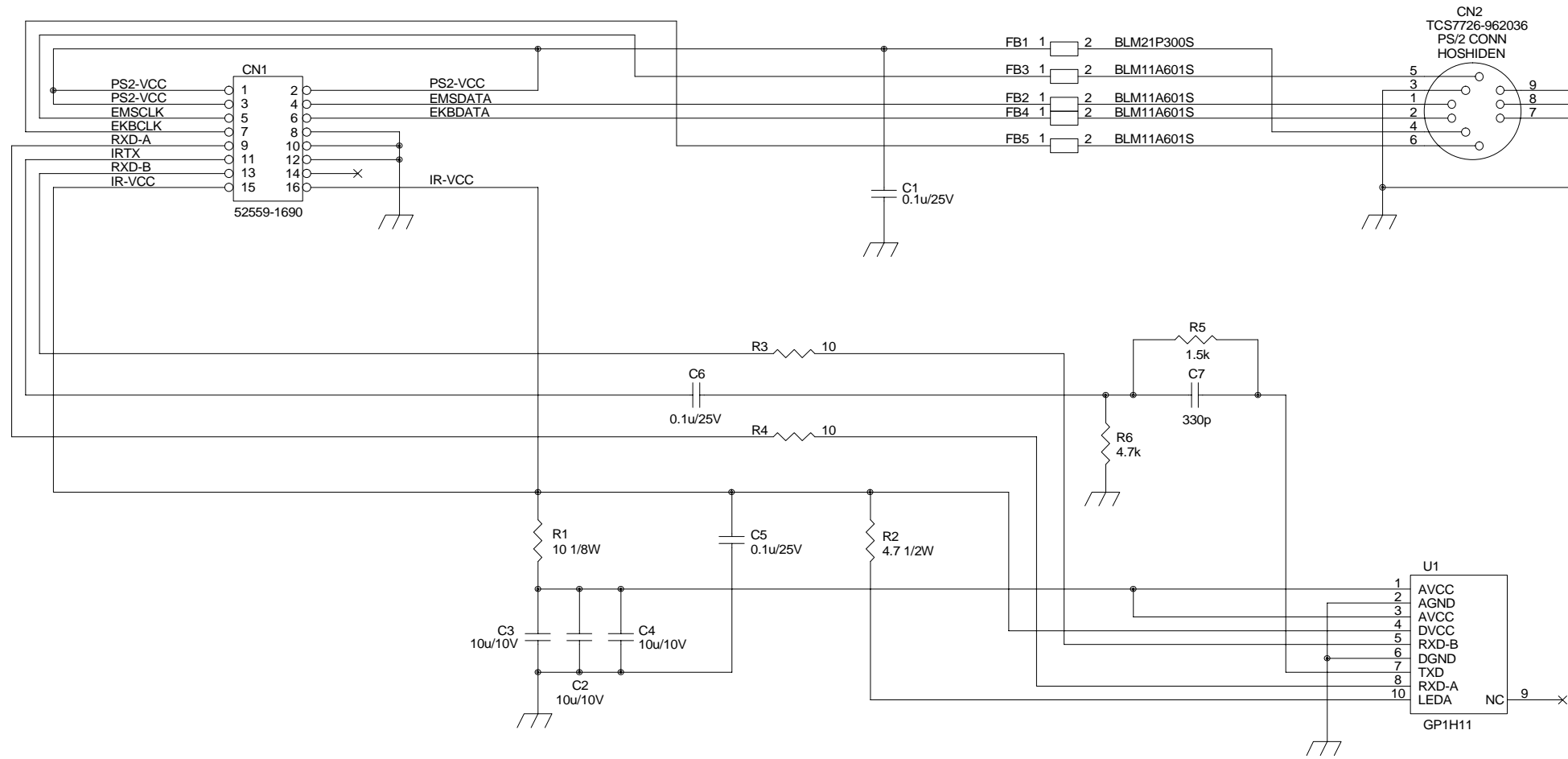

PJ-1 LED PCB (REV 1.0)

1/1

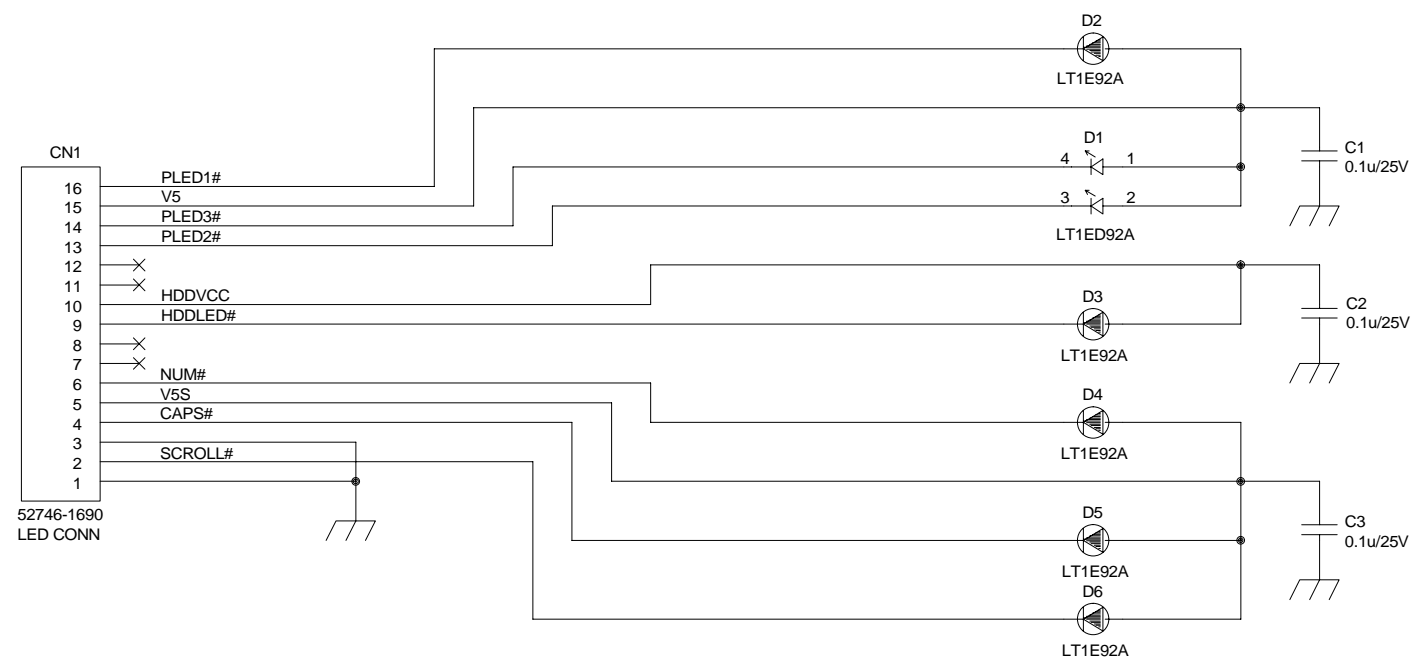

**PARTS LAYOUT**  
**SIDE A**

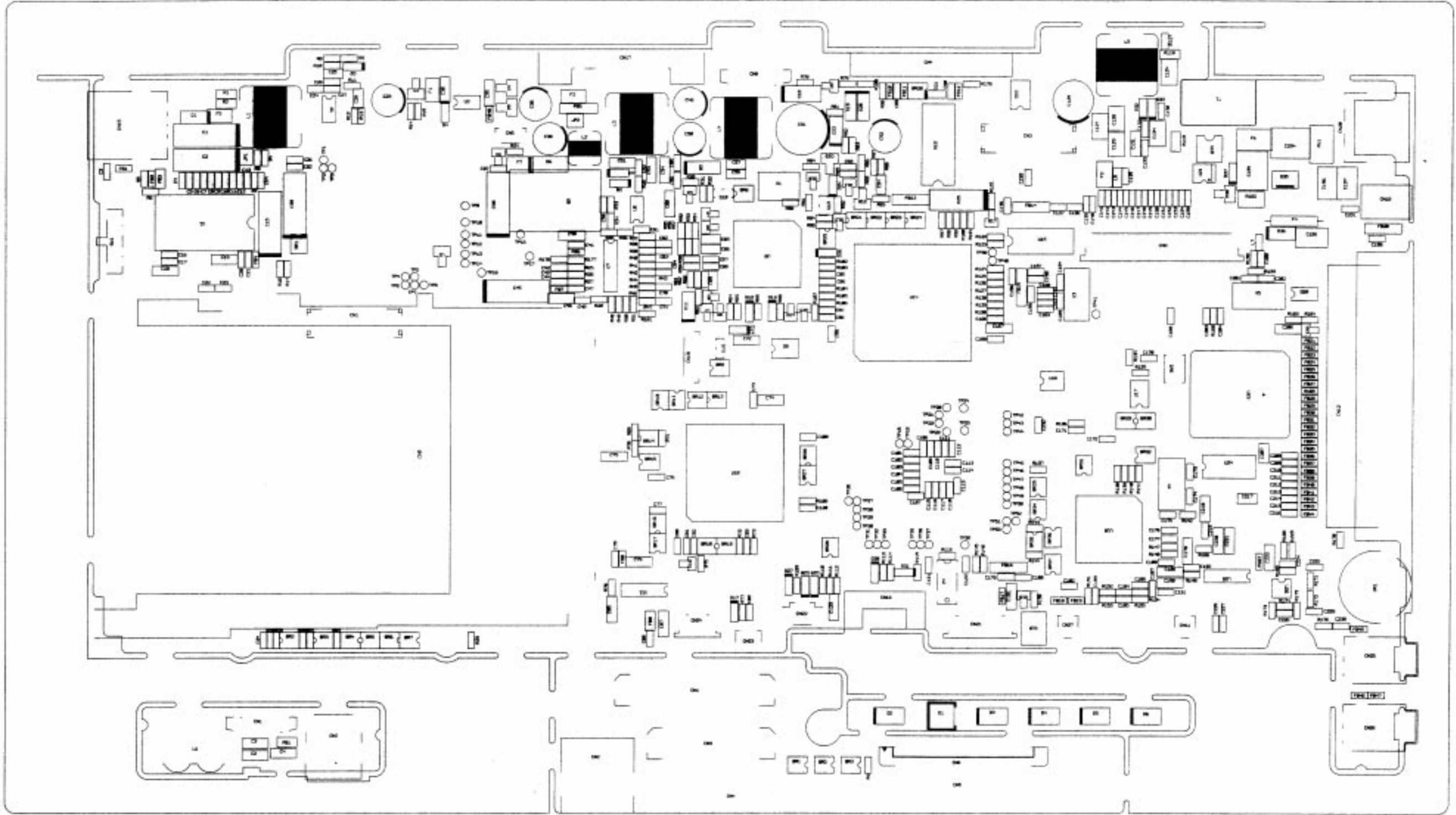

SIDE B

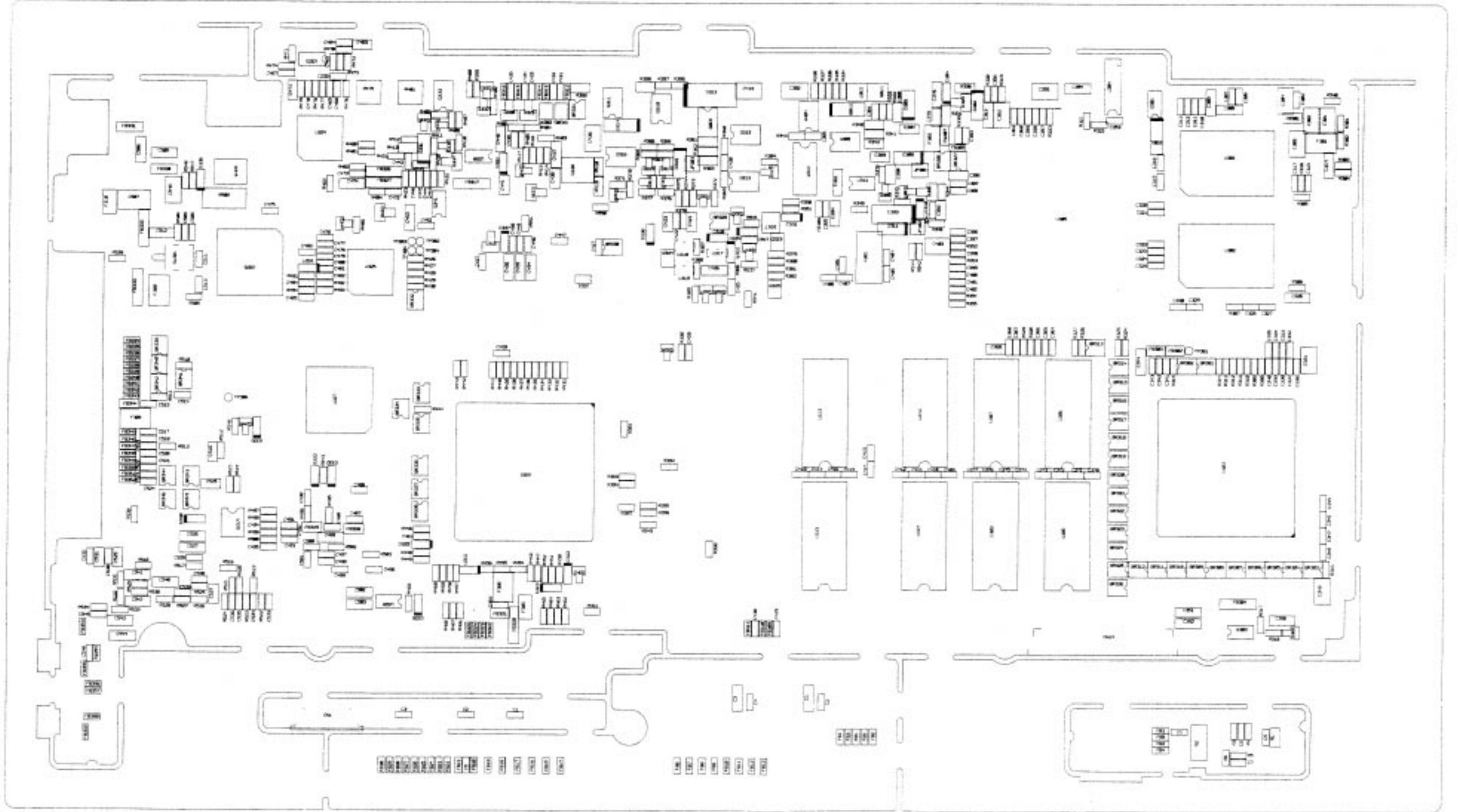

# SHARP

**COPYRIGHT © 1998 BY SHARP CORPORATION**

All rights reserved.

Printed in Japan.

No part of this publication may be reproduced,  
stored in a retrieval system, or transmitted.

In any form or by any means,  
electronic, mechanical, photocopying, recording, or otherwise,  
without prior written permission of the publisher.

**SHARP CORPORATION**  
**Printing Reprographic Systems Group**  
**Quality & Reliability Control Center**  
**Yamatokoriyama, Nara 639-1186, Japan**

1998 September Printed in Japan ©